

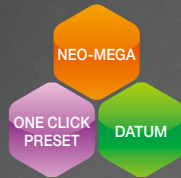

In addition to its MEGA power,
the FS-N Series introduces unprecedented setup ease
with one click operation.

FS-neo



EtherCAT

EtherNet/IP

DeviceNet

CC-Link V2



Certainty and simplicity

There are two major qualities that are important in fiber sensors.

First, the sensor must have improved basic performance, including ample beam power and accuracy, for greater detection stability.

Second, the sensor must be easy for anyone to setup and operate.



Instant alarm readout!

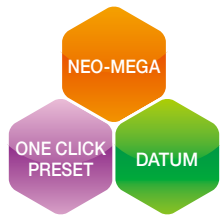

FS-neo

New Concept

Complete setting in just one click

ONE CLICK PRESET

An entirely new concept in setup ease. Just one click calibrates the sensitivity and resets the display.



New Concept

Automatic maintenance

DATUM

The sensor automatically detects reduced light intensity due to debris build-up and automatically re-calibrates to the original display state.



Simple, Convenient

High power reduces labor hours

NEO-MEGA

Increased sensor power greatly reduces maintenance and setup time.

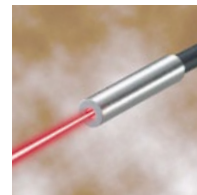

NEO is supported by the world's highest level of performance

World's most powerful beam	World's most accurate	World's highest ambient-light resistance
Achieves 250 times more light intensity	Detects wire as small as ∅0.6 μm (0.024 mil)	Unaffected up to 30,000 lux

New Concept

Complete setting in just one click

Click the button once to simultaneously set the sensitivity and reset the display value to 100.

What customers are saying

“ I usually just set the sensitivity.
It would be nice if I could reset all of the
settings and current values,
**but I wouldn't use this feature
if it's complicated.** ”

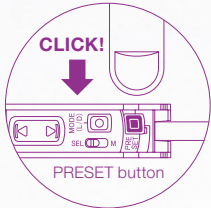
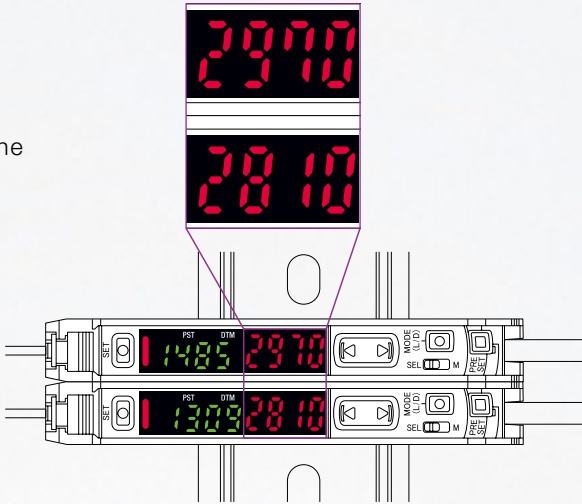

“ With the NEO, just one click
**sets the sensitivity and
resets the display!** ”

All values
reset to
100



Point 1 Easy to detect changes (preventive maintenance)

The NEO provides an easy-to-read indication when the light intensity drops due to dirt or other environment related causes.

Conventional problem

Light intensity reduction is difficult to grasp due to individual differences in numeric values.

Failure!

FS-NEO

All sensors initially display 100, making it easy to detect changes.

Failure!

Easy to tell the value has changed

Point 2 The digital value resets to exactly 100

Conventional problem

The value easily shifted and the initial value of 2000 was arbitrary.

Never reaches exactly 2000

Setting the value to an easier to read value of 1000 required a complicated operation. The ability to change the target value made it difficult to keep track of the original value.

FS-NEO

The numbers reset to exactly 100. The set values are reset to 50.

Set value reset to 50

Display value reset to exactly 100

Resetting numeric values with one click offers unprecedented operating ease.

Point 3 Greater convenience when using multiple sensors

Correction required

Light intensity drop

The preset function is even more useful when using multiple sensors. Quickly and easily locate sensors that have become dirty or misaligned. Main and expansion unit sensors can be reset with one click by pressing PRESET on the main unit.

If the light intensity drops

CLICK!
PRESET button

Pressing PRESET resets to the initial state.

If the light intensity drops significantly it will not return to 100.0, making it easy to detect the problem. The 2-output type can be used to provide a low light intensity signal to a PLC or similar controller.

New Concept

Automatic maintenance

The automatic maintenance function detects light intensity reduction due to dirt or misalignment, and returns the sensor to its original display state. This feature can cancel the effects of the ambient environment, enabling the sensor to continue to perform highly accurate detections.

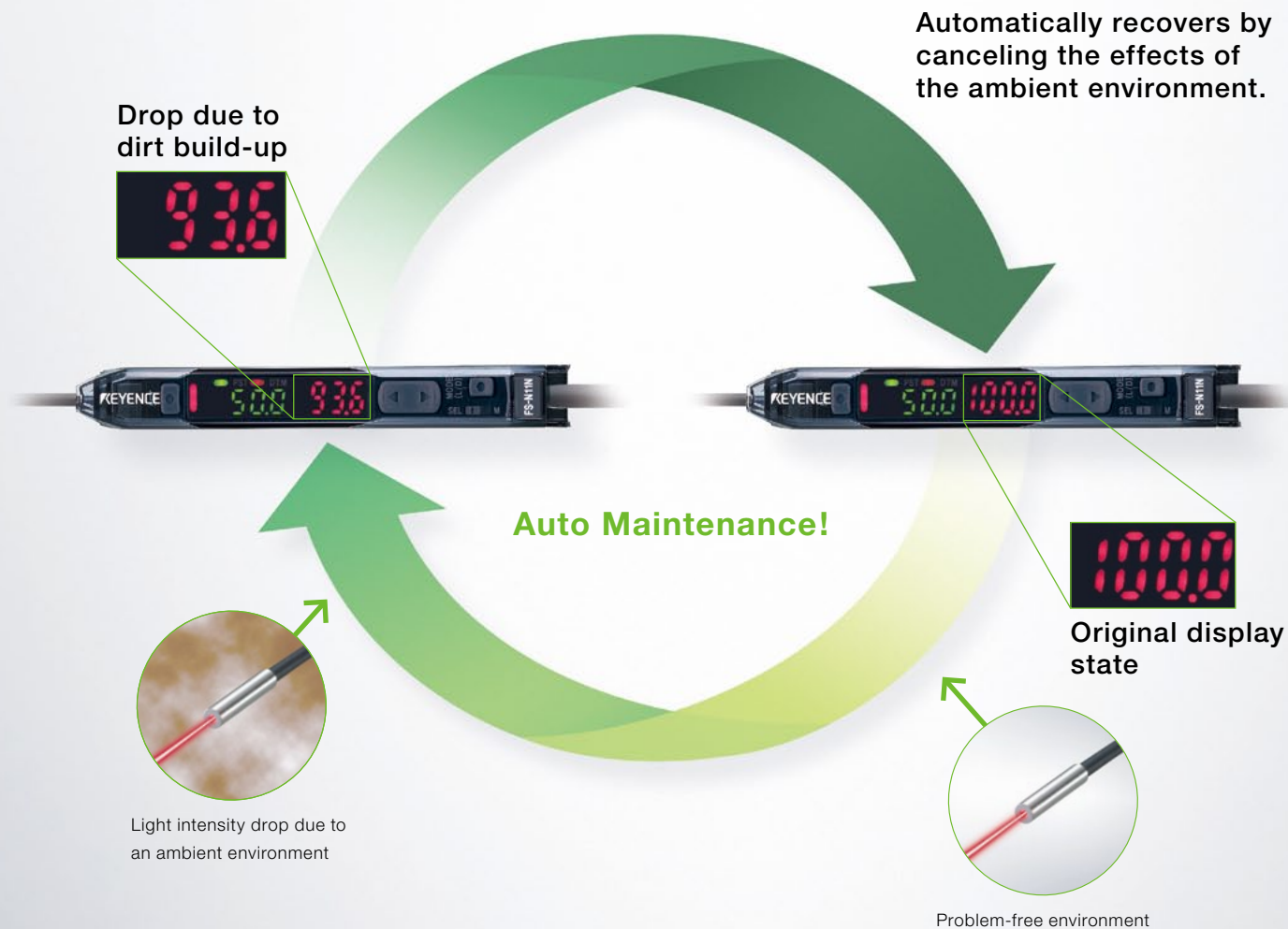

Automatic maintenance function: DATUM

The setting value changes according to the intensity as shown in the figure to the right. This function corrects the setting value based on a running average of the received light intensity value. The correction cycle is the same as the sampling cycle and can be selected from three levels.

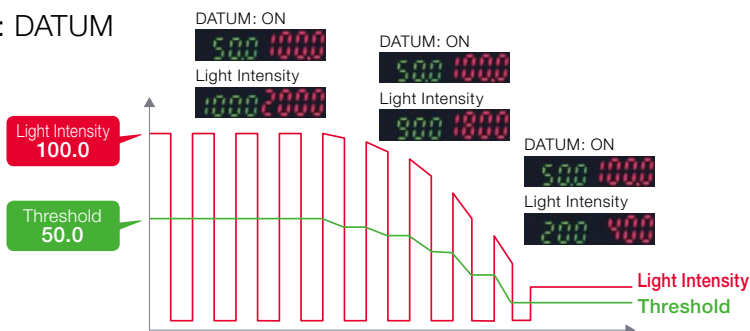

Simple, Convenient

World's highest power reduces maintenance time

"High power" = "large excess gain" that not only reduces the need for maintenance but also expands sensor head capabilities, which reduces setup time.

1

Switch selectable MEGA power

Hassle-free operation allows easy changeover between standard and high power.

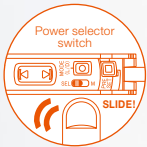

Long distance [MEGA]



Short distance [FINE]



3

Prevent light saturation with a simple operation

Strong light may result in reduced contrast. In this case, simply press the "MODE" + "SET" buttons to automatically adjust the NEO to the proper light intensity.

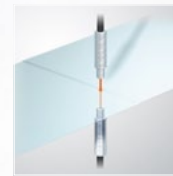

Detecting the seam between transparent films



2

Reduced light intensity variations

With conventional models, amplifying the projected beam of condensed light causes the focus of the beam to be sensitive to minute positioning errors in the light-emitting device. The NEO-LED solves this positioning problem by using a reflector around the light emitting source. The reflector reduces light intensity variations.

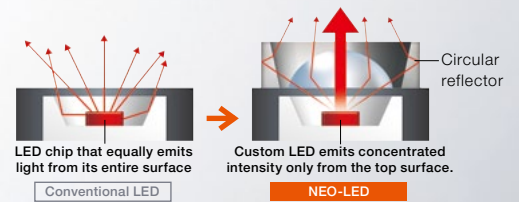

The circular reflector helps compensate for light positioning errors by redirecting any stray light back into the fiber.

World's most powerful beam: NEO-MEGA

Guideline for received light intensity

250 times greater than conventional models

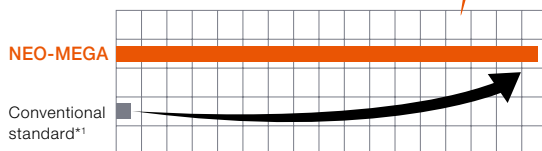

The emitted light intensity is about 4 times stronger than conventional models.

*1. FS-V30 Series in FINE mode

NEO-MEGA, the world's most powerful beam, allows for significant improvement of repeatability and hysteresis.

Repeatability (Typical)

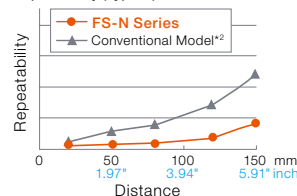

Hysteresis characteristics (Typical)

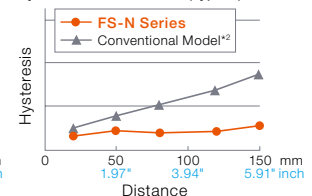

*2. FS-V30 Series

Convenient functionality designed for ease of use in the field

Using the external calibration input*

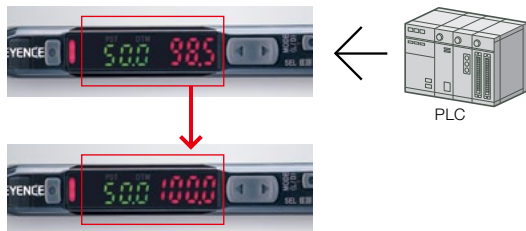

The sensor can be calibrated from a PLC or other external device. Regularly executing the Preset function from an external input ensures uninterrupted, stable detection, even in harsh environments. The 2-output type can be used to provide a low light intensity signal if the sensor becomes extremely dirty.

* Available on models with external input support.

Easy sensitivity setting (two-point tuning)



Set by simply pressing the SET button once with the target present, and once without it.

Program memory

Operators or users may accidentally change the settings on the FS. In this case, conventional models require resetting. The FS-N saves your application settings into memory for fast recovery.

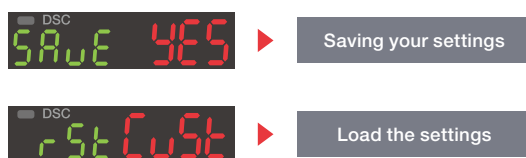

Wire saving when adding sensors



When adding sensors, the power is supplied from the connector on the side. This reduces wiring by two cables per sensor, allowing for a neater, quicker installation.

Note: Only supports FS-N Series amplifiers.

Reliable even when using multiple sensors

All models equipped with a standard heat sink. The heat sink reduces the temperature of the amplifier, and reduces the stress on the LED light source as well as other internal parts.



Zero Shift

Setting the current value to "0" just got easier. Simply press the PRESET and RIGHT button at the same time.



Using a NEO amplifier with an external input, the Zero Shift adjustment can be performed on a regular basis using a PLC or other external device.

World's first power booster switch

The highest power setting can be selected with a DIP switch.



Complete lineup

Cable Type

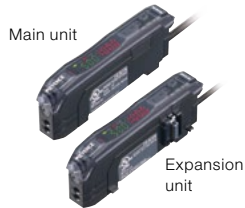

Type	Model	Model		Control outputs	External input	Analog output
		NPN output	PNP output			
Standard	Main unit	FS-N11N	FS-N11P	1	0	0
	Expansion unit	FS-N12N	FS-N12P			
2-output	Main unit	FS-N13N	FS-N13P	2	1	
	Expansion unit	FS-N14N	FS-N14P			
Analog	Main unit	FS-N11MN	—	1	0	1

Connector Type (M8)

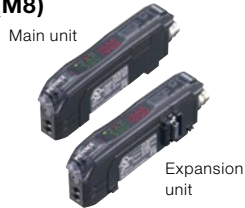

Type	Model	Model		Control outputs	External input	Analog output
		NPN output	PNP output			
Standard	Main unit	FS-N11CN	FS-N11CP	1	1	0
	Expansion unit	FS-N12CN	FS-N12CP			
2-output	Main unit	—	FS-N13CP	2	0	
	Expansion unit	—	FS-N14CP			

0-line Type



Type	Model	Control outputs	External input	Analog output
Expansion unit (No output cable)	FS-N10	1	0	0

Optional (sold separately)

Amplifier securing bracket (for main unit)

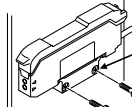

Description	Model
Can be installed without a DIN-rail. Can be installed from above or from the side.	 OP-73880

End unit (when using expansion units)

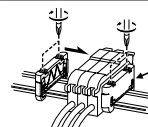

Used to secure the main and expansion units. (Two per set)	 OP-26751 (Two per set)
---	--

M8 connector cable (2 m (6.56')/10 m (32.81'))



Used to connect to the M8 connector type amplifier (model numbers end with a "CN" or "CP"). Connector cables are not included with the amplifier.	 2 m (6.56') type OP-73864
	10 m (32.81') type OP-73865

Expansion converter unit



The FS-N Series has different amplifier connection connectors than the FS-V30, LV, and CZ series. This is an adapter to connect these models. It supplies power from the main unit to the expansion unit and prevents interference. *Communication is not supported.	OP-87199
---	----------

Dramatic reduction in wiring and installation time

Conventional Method

Multiple preparation and wiring steps increased the installation time.

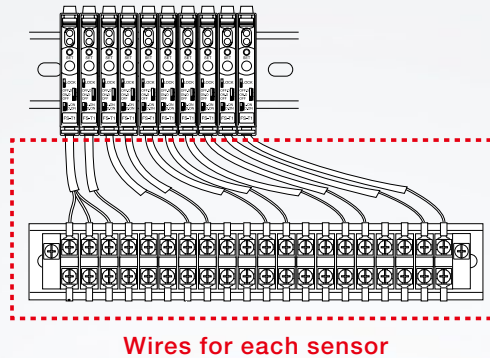

Conventional Wiring

Trim each cable for wiring to the terminal block. Identify and mark each cable.

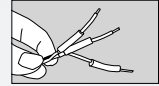

Apply terminal connectors.

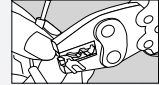

Tighten the screws on the terminal block to connect each sensor.



With the NU Series

Reduced Wiring

Only a single communication cable is required between the PC/PLC and the NU Series for wiring.

- ▶ No need to trim the cables
- ▶ No need for a terminal block
- ▶ No need for a complicated cable layout
- ▶ No additional wiring when replacing sensors



No wires

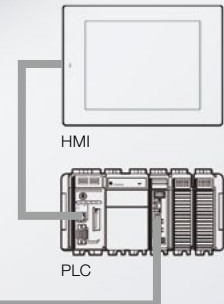

When using 10 amplifiers that are connected in series.

Conventional wiring (Series connection)
 50 min.

NU Series
 5 min. 90% less time than the conventional installation process

Lineup



CC-Link Compatible Network Unit
NU-CL1



DeviceNet Compatible Network Unit
NU-DN1



EtherNet/IP Compatible Network Unit
NU-EP1



EtherCAT Compatible Network Unit
NU-EC1



Digital Fiberoptic Sensor
FS-N10



e-CON Network Input Unit
NU-EN8N

Improved functionality through remote access

Status monitoring, settings changes, and setup backup/recovery can be done via HMI, PLC, or PC.

Conventional Method

With the NU Series

Monitoring

It is desired to prevent false detection by the sensor before it stops production. However, there is no way to monitor it without looking at each sensor.



The sensor status can be monitored on an HMI, PLC or PC, making it easier to detect problems before errors occur.

Tooling change (setting value change)

If multiple products are manufactured on the same line, settings need to be adjusted for each sensor during changeover.



The NU allows for settings to be changed externally from an HMI, PLC or PC. As a result, changeover time can be reduced, even where sensor settings must be changed frequently.

Settings backup/recovery

When shipping a machine, it is necessary to provide setting procedure details for the sensors. Assembling this information can be quite time consuming.



When shipping a machine, backup settings can be quickly saved on an HMI, PLC or PC. Recovering these settings is quick and easy.

System configuration image

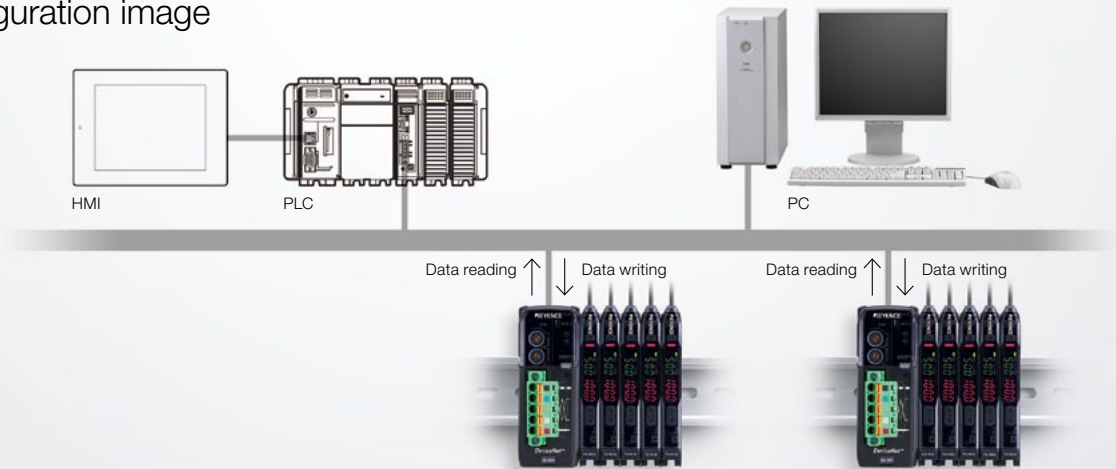

Also available: Sensor input unit

Network Sensor Input Unit **NU-EN8N**

Sensor and switch outputs can be connected with an e-CON (wireless) connector (OP-84338 set of 2), making it possible to monitor their ON/OFF status on an HMI, PLC, or PC.



Photoelectric sensor

Laser sensor

Pressure sensor



Fiber Unit FU Series

Fiber Unit [FU Series]

Choose from our selection of more than 100 types of fiber units.



Standard Type



▶ P.15

Integrated Bracket

The sensor is integrated into an L-shaped bracket, which simplifies installation.

Standard Type



▶ P.15

Flat

This thin profile sensor comes with mounting holes for installation where space is limited.

Standard Type



▶ P.16

Threaded and Hex-shaped Fibers

Threaded for easy mounting onto brackets and machine equipment.

Standard Type

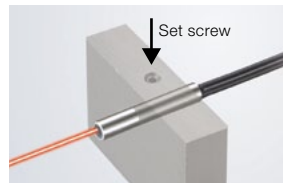

▶ P.18

Cylinder

Small size is suitable for installation in locations where space is limited. Installed by drilling a hole and using a set screw.

Standard Type



▶ P.19

Sleeve

The fiber tip is a thin sleeve. Eliminate problems caused by limited mounting space. Lineup includes side-view and bendable sleeve types.

Focused Beam Type



▶ P.20

Small Spot Reflective

Ideal for detecting small objects. Spot size and focal distance are adjustable, so there is no need to change the distance between the sensor and the target.

High-power Beam Type



▶ P.21

Area

This sensor forms a wide-area beam, making it ideal for moving-target applications, such as detection of falling objects.

High-power Beam Type

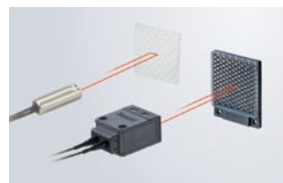

▶ P.21

Retro-reflective

The use of a reflector in place of the receiver used with thru-beam sensors simplifies installation and optical axis alignment. This sensor is suitable for detecting transparent objects.



High-power Beam Type



▶ P.22

Narrow Beam/High-power

Narrow field of view based on focused aperture angle. This sensor reduces stray light for stable target detection. The high-power reflective type with an 8° aperture angle is suitable for detecting objects at longer distances.

Fixed Range Type



▶ P.22

Definite-reflective

Detects within a fixed distance. Reduces the effect of background, and features a space-saving thin-profile design.

High-flex

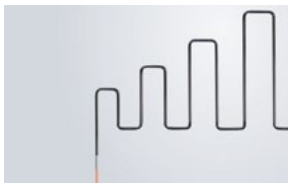

▶ P.23

High-flex*

The R2 (R0.08") ToughFlex fiber achieves excellent flexing characteristics with the same bend radius.
* 10 million bends

Oil/Chemical Resistant



▶ P.23

Oil/Chemical Resistant

The PTFE coating allows these fibers to be used in almost any environment, including oil- or chemical-splash conditions.

Heat Resistant

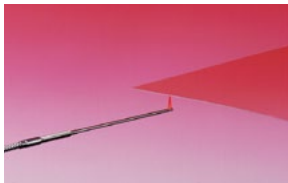

▶ P.24

Heat Resistant

Ideal for use in high temperature applications. Withstands temperatures up to 350°C (662°F).

Application-specific Type



▶ P.25

Liquid-level

Detects liquid levels when immersed or attached to a transparent tube.

Application-specific Type

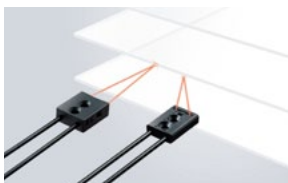

▶ P.25

**Liquid Crystal/
Semiconductors**

Perfect for glass substrate detection. Lineup offers distance alignment, edge detection, and wafer mapping types.

Model search

Model	Page
FU-10	▶ P.20
FU-11	
FU-12	▶ P.21
FU-13	
FU-15	
FU-16	
FU-16Z	▶ P.22
FU-18	
FU-18M	▶ P.22, 25
FU-20	▶ P.20
FU-21X	▶ P.17
FU-22X	▶ P.18, 19
FU-23X	▶ P.18
FU-24X	▶ P.17
FU-25	
FU-31	
FU-32	▶ P.19
FU-33	
FU-34	
FU-35FA	
FU-35FG	
FU-35FZ	▶ P.17
FU-35TG	
FU-35TZ	
FU-37	▶ P.22
FU-38	
FU-38H	▶ P.24, 25
FU-38K	
FU-38L	▶ P.25
FU-38LK	▶ P.24, 25
FU-38R	▶ P.25
FU-38S	
FU-38V	▶ P.22, 25
FU-4F	▶ P.18
FU-4FZ	
FU-40	▶ P.22
FU-40G	
FU-40S	▶ P.25
FU-41TZ	▶ P.15
FU-42TZ	
FU-43	▶ P.19
FU-44TZ	▶ P.15
FU-45X	▶ P.18, 19
FU-46	
FU-47TZ	▶ P.15
FU-48	▶ P.18, 23

Model	Page
FU-48U	▶ P.23
FU-49U	
FU-49X	▶ P.18, 23
FU-5F	▶ P.18
FU-5FZ	
FU-50	▶ P.22
FU-51TZ	
FU-52TZ	▶ P.15
FU-53TZ	
FU-54TZ	
FU-55	▶ P.18
FU-56	▶ P.18, 19
FU-57TE	▶ P.23
FU-57TZ	▶ P.15
FU-58	▶ P.18
FU-58U	▶ P.23
FU-59	▶ P.18, 23
FU-59U	▶ P.23
FU-6F	
FU-61	▶ P.17
FU-61Z	
FU-63	
FU-63T	▶ P.19
FU-63Z	
FU-65X	
FU-66	
FU-66TZ	
FU-66Z	
FU-67	▶ P.17
FU-67G	
FU-67TG	
FU-67TZ	
FU-67V	
FU-68	
FU-69U	▶ P.23
FU-69X	
FU-7F	▶ P.16
FU-70U	▶ P.23
FU-71	▶ P.16
FU-71Z	
FU-73	
FU-75F	▶ P.19
FU-76F	
FU-77	
FU-77G	▶ P.16
FU-77TG	

Model	Page
FU-77TZ	
FU-77V	▶ P.16
FU-78	
FU-79	▶ P.23
FU-79U	
FU-81C	
FU-82C	
FU-83C	
FU-84C	
FU-85A	
FU-85H	
FU-85Z	▶ P.24
FU-86A	
FU-86H	
FU-86Z	
FU-87	
FU-87K	
FU-88	
FU-88K	
FU-91	▶ P.23
FU-92	
FU-93	
FU-93Z	
FU-95	
FU-95HA	▶ P.25
FU-95S	
FU-95W	
FU-95Z	
FU-96	▶ P.23
FU-A05	
FU-A05D	
FU-A10	▶ P.21
FU-A10D	
FU-E11	
FU-E40	
FU-L50Z	
FU-L51Z	
FU-L52Z	▶ P.15
FU-L53Z	
FU-L54Z	
FU-L41Z	

Integrated Bracket

Integrated bracket and sensor simplifies installation.

Thrubeam/reflective types

Detecting method	Type		Fiber unit length (Diameter) Ambient temperature	Appearance (mm inch)	Minimum bend radius (mm inch)	Detecting distance (mm inch)*1		Optical axis diameter (mm inch) (Standard target to be detected)	Model Weight				
	Beam emitting direction	Optical axis height (mm inch)				MEGA FINE	Other power modes						
Thrubeam	Top	10 0.39"	2 m 6.56' Free-cut (ø2.2 ø0.09") -40 to +50°C -40 to +122°F		R2 R0.08" ToughFlex	MEGA: 2200 FINE: 450	ULTRA: 1700 SUPER: 1000 TURBO: 760 HSP: 290	ø1.13 ø0.04"	FU-L51Z Approx. 30 g				
		15 0.59"	2 m 6.56' Free-cut (ø2.2 ø0.09") -40 to +50°C -40 to +122°F							MEGA: 2200 FINE: 450	ULTRA: 1700 SUPER: 1000 TURBO: 760 HSP: 290	ø1.13 ø0.04"	FU-L52Z Approx. 30 g
		20 0.79"	2 m 6.56' Free-cut (ø2.2 ø0.09") -40 to +50°C -40 to +122°F										
	Top (lens)	10 0.39"	2 m 6.56' Free-cut (ø2.2 ø0.09") -40 to +50°C -40 to +122°F			MEGA: 1900 FINE: 410	ULTRA: 1500 SUPER: 900 TURBO: 700 HSP: 270	ø1.13 ø0.04"	FU-L54Z Approx. 30 g				
	Side	10 0.39"	2 m 6.56' Free-cut (ø2.2 ø0.09") -40 to +50°C -40 to +122°F							MEGA: 760 FINE: 170	ULTRA: 580 SUPER: 430 TURBO: 320 HSP: 90	-	FU-L41Z Approx. 25 g
Reflective	Top	10 0.39"	2 m 6.56' Free-cut (ø2.2 ø0.09") -40 to +50°C -40 to +122°F										

*1 Detecting distance for reflective fibers is based on a standard target: White matte paper.

Flat

Mount directly in locations where space is limited.

Thrubeam/reflective types



Detecting method	Type		Fiber unit length (Diameter) Ambient temperature	Appearance (mm inch)	Minimum bend radius (mm inch)	Detecting distance (mm inch)*1		Optical axis diameter (mm inch) (Standard target to be detected)	Model Weight
	Beam emitting direction	Optical axis height (mm inch)				MEGA FINE	Other power modes		
Thrubeam	Top	10 0.39"	1 m 3.28' Free-cut (ø1.0 ø0.04") -40 to +50°C -40 to +122°F		R2 R0.08" ToughFlex	MEGA: 810 FINE: 170	ULTRA: 520 SUPER: 340 TURBO: 260 HSP: 90	ø0.5 ø0.02"	FU-51TZ Approx. 5 g
		14 0.55"	2 m 6.56' Free-cut (ø1.3 ø0.05") -40 to +50°C -40 to +122°F						
	Side	10.5 0.41"	1 m 3.28' Free-cut (ø1.0 ø0.04") -40 to +50°C -40 to +122°F			MEGA: 740 FINE: 140	ULTRA: 480 SUPER: 280 TURBO: 200 HSP: 70	ø0.5 ø0.02"	FU-57TZ Approx. 5 g
		Flat	10.5 0.41"	1 m 3.28' Free-cut (ø1.0 ø0.04") -40 to +50°C -40 to +122°F					
	15 0.59"		2 m 6.56' Free-cut (ø2.2 ø0.09") -40 to +50°C -40 to +122°F			MEGA: 2900 FINE: 610	ULTRA: 1900 SUPER: 1200 TURBO: 850 HSP: 260	ø1 ø0.04"	FU-54TZ Approx. 25 g
Reflective	Top	6.5 0.26"	1 m 3.28' Free-cut (ø1.0 ø0.04" x 2) -40 to +50°C -40 to +122°F		R2 R0.08" ToughFlex				
	Side	10.5 0.41"	1 m 3.28' Free-cut (ø1.0 ø0.04" x 2) -40 to +50°C -40 to +122°F			MEGA: 2 to 120 FINE: 2 to 24	ULTRA: 2 to 77 SUPER: 2 to 50 TURBO: 2 to 32 HSP: 2 to 8	0.08" to 3.03" 0.08" to 1.97" 0.08" to 1.26" 0.08" to 0.32"	FU-41TZ Approx. 5 g
	Flat	7 0.28"	1 m 3.28' Free-cut (ø1.0 ø0.04") -40 to +50°C -40 to +122°F						
		7 0.28"	2 m 6.56' Free-cut (ø2.2 ø0.09" x 2) -40 to +50°C -40 to +122°F						

*1 Detecting distance for reflective fibers is based on a standard target: White matte paper.

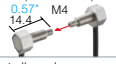
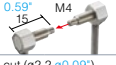
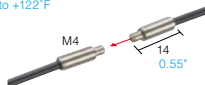
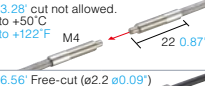
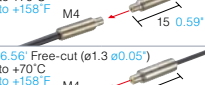
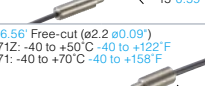

Threaded and Hex-shaped Fibers

Most common fiber sensor.
Easily mounts onto brackets or machine equipment.

Thrubeam

Detecting method	Type	Fiber unit length (Diameter) Ambient temperature	Appearance (mm inch)	Minimum bend radius (mm inch)	Detecting distance (mm inch)		Optical axis diameter (mm inch) (Standard target to be detected)	Model Weight	
					MEGA FINE	Other power modes			
Thrubeam	Hex-shaped	2 m 6.56' Free-cut (ø2.2 ø0.09") -40 to +50°C -40 to +122°F		R2 R0.08" ToughFlex	MEGA: 3100 FINE: 640	122.05" 25.20"	ULTRA: 2100 82.68"	FU-77TZ Approx. 43 g	
							SUPER: 1300 51.18"		
	Hex-shaped	1 m 3.28' cut not allowed. -40 to +50°C -40 to +122°F		R10 R0.39" Stainless Steel	MEGA: 1800 FINE: 640	70.87" 25.20"	ULTRA: 1800 70.87"	FU-77TG Approx. 43 g	
							SUPER: 1300 51.18"		
	M4	Threaded	2 m 6.56' Free-cut (ø2.2 ø0.09") -40 to +50°C -40 to +122°F		R0.5 R0.02" ToughFlex	MEGA: 3600 FINE: 880	141.73" 34.65"	ULTRA: 3000 118.11"	FU-77V Approx. 25 g
					R2 R0.08" ToughFlex			ULTRA: 1800 70.87"	
		Threaded	1 m 3.28' cut not allowed. -40 to +50°C -40 to +122°F		R10 R0.39" Stainless Steel	MEGA: 1800 FINE: 880	70.87" 34.65"	ULTRA: 1800 70.87"	FU-77G Approx. 39 g
								SUPER: 1300 51.18"	
		Threaded	2 m 6.56' Free-cut (ø1.3 ø0.05") -40 to +70°C -40 to +158°F		R25 R0.98"	MEGA: 3600 FINE: 1100	141.73" 43.31"	ULTRA: 3200 125.98"	FU-7F Approx. 21 g
								SUPER: 2200 86.61"	
Threaded	2 m 6.56' Free-cut (ø1.3 ø0.05") -40 to +70°C -40 to +158°F		R4 R0.16"	MEGA: 2200 FINE: 440	86.61" 17.32"	ULTRA: 1400 55.12"	FU-78 Approx. 9 g		
						SUPER: 860 33.86"			
M6	Threaded	2 m 6.56' Free-cut (ø2.2 ø0.09") -40 to +50°C -40 to +122°F FU-71Z: -40 to +70°C -40 to +158°F		R2 R0.07" ToughFlex	MEGA: 3600 FINE: 1100	141.73" 43.31"	ULTRA: 3600 141.73"	FU-71Z Approx. 25 g	
				R25 R0.98"			SUPER: 2300 90.55"		
M6	Threaded	2 m 6.56' Free-cut (ø2.2 ø0.09") -40 to +50°C -40 to +122°F FU-71: -40 to +70°C -40 to +158°F		R25 R0.98"	MEGA: 3600 FINE: 1300	141.73" 51.2"	ULTRA: 3600 141.73"	FU-71 Approx. 25 g	
				R25 R0.98"			SUPER: 2600 90.55"		

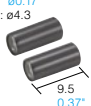
Thrubeam Lenses

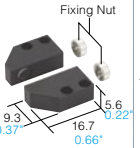
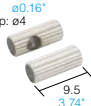
Type	Ambient temperature Appearance (mm inch)	Model Weight	Applicable fiber units	Detecting distance (mm inch)**					
				MEGA	ULTRA	SUPER	TURBO	FINE	HSP
Ultra-long detecting distance Narrow field of view Aperture Angle: Approx. 8°	Heat Resistance: 70°C 158°F Tip: ø4.3 	F-4 Approx. 1 g	FU-77TZ/77V/77						2700 106.30"
			FU-7F			3600 141.73"			3200 125.98"
			FU-78						2200 86.61"
			FU-77G/77TG			1800 70.87"			
Long-detecting distance Aperture Angle: Approx. 15°	Heat Resistance: 300°C 572°F Tip: ø4 	F-2 Approx. 2 g	FU-77TZ/77V/77/84C/88K			3600 141.73"			2100 82.68"
			FU-7F/86A			3600 141.73"			2500 98.43"
			FU-86Z			3600 141.73"			1900 74.80"
			FU-78			3600 141.73"		3300 129.92"	1600 62.99"
			FU-77G/77TG			1800 70.87"			
Side-view with mounting holes	Heat Resistance: 105°C 221°F Fixing Nut 	F-5 Approx. 10 g	FU-77V/77						2600 102.36"
			FU-7F/86A						3100 122.05"
			FU-86Z			3600 141.73"			2900 114.17"
			FU-78					2300 90.55"	
			FU-77G			1800 70.87"			
Side-view	Heat Resistance: 70°C 158°F ^{1,2} Tip: ø4 	F-1 Approx. 2 g	FU-77V/77	3600 141.73"	3100 122.05"	1900 74.80"	1300 51.18"	900 35.43"	530 20.87"
			FU-77G		1800 70.87"		1300 51.18"	900 35.43"	530 20.87"
			FU-7F/86A	3600 141.73"		3100 122.05"	2100 82.68"	1300 51.18"	630 24.80"
			FU-86Z	3600 141.73"	3300 129.92"	2300 90.55"	1500 59.06"	1100 43.31"	500 19.69"
			FU-78/84C/88K	3200 125.98"	2500 98.43"	1600 62.99"	1100 43.31"	800 31.50"	360 14.17"

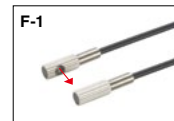
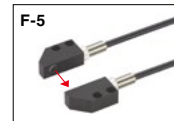
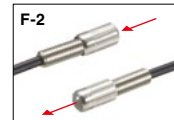
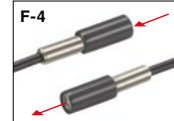

¹ The maximum sensing distance of 3600 mm (141.73" (1800 mm 70.87")) is possible because the fiber length on each side is 2 m 6.56' (1 m 3.28').
² When using the F-1 at 70°C 158°F or more, specify the "Heat-resistant F-1". Be sure to use the "Heat-resistant F-1" at a constant temperature.

Reflective

Detecting method	Type		Fiber unit length (Diameter) Ambient temperature	Appearance (mm inch)	Minimum bend radius (mm inch)	Detecting distance (mm inch)*1			Model Weight	
	Size/Shape	Detecting arrangement				MEGA FINE	Other power modes			
Reflective	M3	Hex-shaped	1 m 3.28' Free-cut (ø1.3 ø0.05 x 2) -40 to +50°C -40 to +122°F		R2 R0.08* ToughFlex	MEGA: 400 15.75*	ULTRA: 270 10.63*	FU-35TZ Approx. 7 g		
						FINE: 70 2.76*	SUPER: 170 6.69*			
		Threaded	Coaxial	1 m 3.28' Free-cut (ø1.3 ø0.05 x 2) -40 to +50°C -40 to +122°F		R10 R0.39* Stainless Steel	MEGA: 450 17.72*	ULTRA: 290 11.42*	FU-35FZ Approx. 6 g	
				1 m 3.28' Free-cut (ø1.3 ø0.05 x 2) Spiral 30 cm -40 to +50°C -40 to +122°F			FINE: 72 2.76*	SUPER: 190 7.48*	FU-35FG Approx. 15 g	
				1 m 3.28' Free-cut (ø1.3 ø0.05 x 2) -40 to +70°C -40 to +158°F			Lens attachment: P.18	TURBO: 115 4.53*	FU-35FA Approx. 6 g	
	Threaded	Coaxial	50 cm 1.64' cut not allowed. FU-21X: -40 to +70°C -40 to +158°F FU-24X: -40 to +50°C -40 to +122°F		R25 R0.98*	MEGA: 550 21.65*	ULTRA: 400 15.75*	FU-21X Approx. 4 g		
						FINE: 110 4.33*	SUPER: 250 9.84*			
	Reflective	M4	Hex-shaped	2 m 6.56' Free-cut (ø1.3 ø0.05 x 2) -40 to +50°C -40 to +122°F		R2 R0.08* ToughFlex	MEGA: 640 25.2*	ULTRA: 420 16.54*	FU-66TZ Approx. 10 g	
							FINE: 140 5.51*	SUPER: 320 12.60*		
			Threaded	Parallel	2 m 6.56' Free-cut (ø1.3 ø0.05 x 2) FU-66Z: -40 to +50°C -40 to +122°F FU-66: -40 to +70°C -40 to +158°F		R25 R0.98*	MEGA: 770 30.32*	ULTRA: 560 22.05*	FU-66Z Approx. 10 g
						FINE: 190 7.48*	SUPER: 380 14.96*	FU-66 Approx. 10 g		
Reflective		M6	Hex-shaped	2 m 6.56' Free-cut (ø2.2 ø0.09 x 2) -40 to +50°C -40 to +122°F		R2 R0.08* ToughFlex	MEGA: 1100 43.31*	ULTRA: 860 33.86*	FU-67TZ Approx. 32 g	
							FINE: 300 11.81*	SUPER: 570 22.44*		
			Hex-shaped	Coaxial	1 m 3.28' cut not allowed. -40 to +50°C -40 to +122°F		R10 R0.39* Stainless Steel	MEGA: 710 27.95*	ULTRA: 470 18.50*	FU-67TG Approx. 32 g
					1 m 3.28' cut not allowed. -40 to +50°C -40 to +122°F			FINE: 210 8.27*	TURBO: 310 12.20*	
					1 m 3.28' cut not allowed. -40 to +50°C -40 to +122°F			Lens attachment: P.18	HSP: 90 3.54*	
		Threaded	Parallel	2 m 6.56' Free-cut (ø2.2 ø0.09 x 2) -40 to +50°C -40 to +122°F		R0.5 R0.02* ToughFlex	MEGA: 900 35.43*	ULTRA: 740 29.13*	FU-67V Approx. 25 g	
	2 m 6.56' Free-cut (ø2.2 ø0.09 x 2) -40 to +50°C -40 to +122°F				FINE: 210 8.27*		SUPER: 490 19.29*			
	2 m 6.56' Free-cut (ø2.2 ø0.09 x 2) -40 to +50°C -40 to +122°F				MEGA: 1200 47.24*		ULTRA: 900 35.43*	FU-61Z Approx. 22 g		
	2 m 6.56' Free-cut (ø2.2 ø0.09 x 2) -40 to +50°C -40 to +122°F				FINE: 300 11.81*		SUPER: 590 23.23*	FU-67 Approx. 21 g		
	Threaded		Coaxial	1 m 3.28' cut not allowed. -40 to +50°C -40 to +122°F		R10 R0.39* Stainless Steel	MEGA: 900 35.43*	ULTRA: 740 29.13*	FU-67G Approx. 29 g	
1 m 3.28' cut not allowed. -40 to +50°C -40 to +122°F					FINE: 210 8.27*		SUPER: 490 19.29*			
1 m 3.28' cut not allowed. -40 to +50°C -40 to +122°F					Lens attachment: P.18		HSP: 110 4.33*	FU-61 Approx. 21 g		
Threaded	Coaxial	2 m 6.56' Free-cut (ø2.2 ø0.09 x 2) -40 to +70°C -40 to +158°F		R25 R0.98*	MEGA: 1300 51.18*	ULTRA: 1000 39.37*	FU-61 Approx. 21 g			
		2 m 6.56' Free-cut (ø2.2 ø0.09 x 2) -40 to +70°C -40 to +158°F			FINE: 380 14.96*	SUPER: 820 32.28*				
Threaded	Coaxial	2 m 6.56' Free-cut (ø2.2 ø0.09 x 2) -40 to +70°C -40 to +158°F		R25 R0.98*	MEGA: 1100 43.31*	ULTRA: 860 33.86*	FU-6F Approx. 21 g			
		2 m 6.56' Free-cut (ø2.2 ø0.09 x 2) -40 to +70°C -40 to +158°F			FINE: 300 11.81*	SUPER: 570 22.44*				
Threaded	Coaxial	2 m 6.56' Free-cut (ø2.2 ø0.09 x 2) -40 to +70°C -40 to +158°F		R25 R0.98*	MEGA: 720 28.35*	ULTRA: 630 24.8*	FU-25 Approx. 18 g			
		2 m 6.56' Free-cut (ø2.2 ø0.09 x 2) -40 to +70°C -40 to +158°F			FINE: 160 6.30*	SUPER: 410 16.14*				

*1 Detecting distance for reflective fibers is based on a standard target: White matte paper.

Cylinder

Small size is suitable for installation in locations where space is limited.
Installed by drilling a hole and using a set screw.

Thrubeam/reflective types

Detecting method	Type Size (mm inch)	Fiber unit length (Diameter) Ambient temperature Appearance (mm inch)	Minimum bend radius (mm inch)	Detecting distance (mm inch)**				Optical axis diameter (mm inch) (Standard target to be detected)	Model Weight
				MEGA FINE		Other power modes			
Thrubeam	ø1.0 ø0.04*	50 cm 1.64' cut not allowed. -40 to +50°C -40 to +122°F ø0.04'ø1 6 0.24'	R10 R0.39*	MEGA: 380 FINE: 85	14.96* 3.35*	ULTRA: 270 SUPER: 180 TURBO: 120 HSP: 40	10.63* 7.09* 4.72* 1.57*	ø0.265 ø0.01*	FU-58 Approx. 8 g
	ø1.5 ø0.06*	1 m 3.28' Free-cut (ø1.0 ø0.04) -40 to +70°C -40 to +158°F ø0.06'ø1.5 10 0.39'	R4 R0.16* High-flex	MEGA: 1200 FINE: 230	47.24* 9.06*	ULTRA: 810 SUPER: 590 TURBO: 410 HSP: 130	31.89* 23.23* 16.14* 5.12*	ø0.7 ø0.03*	FU-59 Approx. 3 g
	ø2.5 ø0.10*	50 cm 1.64' cut not allowed. -40 to +70°C -40 to +158°F ø0.10'ø2.5 10 0.39'	R10 R0.39*	MEGA: 45 FINE: 13	1.77* 0.51*	ULTRA: 32 SUPER: 23 TURBO: 18 HSP: -	1.26* 0.91* 0.71* -	ø0.125 ø005*	FU-55 Approx. 3 g FU-56 Approx. 3 g
	ø3 ø0.12*	2 m 6.56' Free-cut (ø2.2 ø0.09) -40 to +50°C -40 to +122°F ø0.12'ø3 14 0.55'	R2 R0.08* ToughFlex	MEGA: 3600 FINE: 880	171.73* 34.65*	ULTRA: 3000 SUPER: 1800 TURBO: 1300 HSP: 430	118.11* 70.87* 51.18* 16.93*	ø1.13 ø0.04*	FU-5FZ Approx. 19 g
Reflective	ø1.5 ø0.06*	2 m 6.56' Free-cut (ø2.2 ø0.09) -40 to +70°C -40 to +158°F ø0.12'ø3 15 0.59'	R25 R0.98*	MEGA: 3600 FINE: 1100	171.73* 43.30*	ULTRA: 3200 SUPER: 2200 TURBO: 1500 HSP: 540	125.98* 86.61* 59.06* 21.26*	ø1 ø0.04*	FU-5F Approx. 19 g
	ø1.5 ø0.06*	1 m 3.28' cut not allowed -40 to +70°C -40 to +158°F ø1.5 ø0.06* 15 0.59'	R4 R0.16* High-flex	MEGA: 150 FINE: 32	5.91* 1.26*	ULTRA: 100 SUPER: 80 TURBO: 54 HSP: 22	3.94* 3.15* 2.13* 0.87*	-	FU-49X Approx. 3 g
	ø1.5 ø0.06*	1 m 3.28' cut not allowed -40 to +70°C -40 to +158°F ø0.5 ø0.02' ø0.06* 15 0.59'	R10 R0.39*	MEGA: 27 FINE: 4.8	1.06* 0.19*	ULTRA: 18 SUPER: 13 TURBO: 10 HSP: 2.4	0.71* 0.51* 0.39* 0.09*	-	FU-46 Approx. 2 g
	ø2.5 ø0.10*	50 cm 1.64' cut not allowed -40 to +70°C -40 to +158°F ø2.5 ø0.10* 14 0.55'	R25 R0.98*	MEGA: 72 FINE: 23	2.83* 0.91*	ULTRA: 59 SUPER: 45 TURBO: 32 HSP: 12	2.32* 1.77* 1.26* 0.47*	-	FU-22X Approx. 4 g
	ø3 ø0.12*	2 m 6.56' Free-cut (ø1.3 ø0.05 x 2) FU-4FZ: -40 to +50°C -40 to +122°F FU-4F: -40 to +70°C -40 to +158°F ø0.12'ø3 17 0.67'	R2 R0.08* ToughFlex	MEGA: 770 FINE: 190	30.32* 7.48*	ULTRA: 560 SUPER: 380 TURBO: 260 HSP: 80	22.05* 14.96* 10.24* 3.15*	-	FU-4FZ Approx. 8 g
	ø3 ø0.12*	2 m 6.56' Free-cut (ø1.3 ø0.05 x 2) FU-4FZ: -40 to +50°C -40 to +122°F FU-4F: -40 to +70°C -40 to +158°F ø0.12'ø3 17 0.67'	R25 R0.98*	MEGA: 1100 FINE: 300	43.30* 11.81*	ULTRA: 860 SUPER: 570 TURBO: 410 HSP: 140	33.86* 22.44* 16.14* 5.51*	-	FU-4F Approx. 8 g
	ø3 ø0.12*	2 m 6.56' Free-cut (ø1.0 ø0.04 x 2) -40 to +70°C -40 to +158°F ø0.12'ø3 15 0.59'	R4 R0.16* High-flex	MEGA: 290 FINE: 63	11.42* 2.48*	ULTRA: 200 SUPER: 130 TURBO: 80 HSP: 32	7.87* 5.12* 3.15* 1.26*	-	FU-48 Approx. 7 g
	ø3 ø0.12*	50 cm 1.64' cut not allowed -40 to +70°C -40 to +158°F ø0.12'ø3 17 0.67'	R25 R0.98*	MEGA: 830 FINE: 180	32.68* 7.09*	ULTRA: 680 SUPER: 470 TURBO: 320 HSP: 130	26.77* 18.50* 12.60* 5.12*	-	FU-23X Approx. 4 g
	ø3 ø0.12*	50 cm 1.64' cut not allowed -40 to +70°C -40 to +158°F ø0.12'ø3 15 0.59'	R4 R0.16*	MEGA: 68 FINE: 18	2.68* 0.71*	ULTRA: 54 SUPER: 40 TURBO: 27 HSP: 8	2.13* 1.57* 1.06* 0.32*	-	FU-45X Approx. 4 g

**1 Detecting distance for reflective fibers is based on a standard target: White matte paper.

Sleeve

Eliminate problems caused by limited mounting space.

Thrubeam/reflective types

Detecting method	Type	Beam emitting direction	Fiber unit length (Diameter) Ambient temperature	Appearance (mm inch)	Minimum bend radius (mm inch)	Detecting distance (mm inch)**				Optical axis diameter (mm inch) (Standard target to be detected)	Model Weight			
						MEGA FINE		Other power modes						
Thrubeam	Side-view	1 m 3.28' Free-cut (ø1.3 ø0.05") -40 to +70°C ø0.10" ø2.5 -40 to +158°F ø0.82 ø0.03"		R25 R0.98"	MEGA: 520 20.47" FINE: 100 3.94"	ULTRA: 380 14.96" SUPER: 230 9.06" TURBO: 160 6.30" HSP: 55 2.17"	ø0.6 ø0.02"	FU-32 Approx. 5 g						
									2 m 6.56' Free-cut (ø2.2 ø0.09") -40 to +70°C ø1.2 ø0.05" -40 to +158°F ø0.82 ø0.03"	R25 R0.98"	MEGA: 1600 62.99" FINE: 330 12.99"	ULTRA: 1100 43.31" SUPER: 660 25.98" TURBO: 470 18.50" HSP: 140 5.51"	ø1 ø0.04"	FU-34 Approx. 17 g
	Top view	1 m 3.28' Free-cut (ø1.0 ø0.04") -40 to +70°C ø0.03" ø0.82 -40 to +158°F ø0.82 ø0.03"	R10 R0.39"	MEGA: 690 27.17" FINE: 170 6.69"	ULTRA: 500 19.69" SUPER: 340 13.39" TURBO: 240 9.45" HSP: 72 2.83"	ø0.5 ø0.02"	FU-75F Approx. 10 g							
								1 m 3.28' Free-Free-cut (ø1.0 ø0.04") -40 to +70°C ø0.02" ø0.4 -40 to +158°F ø0.4 ø0.3"	R10 R0.39"	MEGA: 370 14.57" FINE: 85 3.35"	ULTRA: 260 10.24" SUPER: 180 7.09" TURBO: 120 4.72" HSP: 40 1.57"	ø0.265 ø0.01"	FU-76F Approx. 10 g	
														50 cm 1.64' cut not allowed -40 to +70°C ø0.10" ø0.01" ø2.5 -40 to +158°F ø0.3 ø0.3"
Reflective	Side	2 m 6.56' Free-cut (ø1.0 ø0.04" x 2) -40 to +70°C ø0.11" ø0.08" ø2.8 -40 to +158°F ø2 ø2		R10 R0.39"	MEGA: 180 7.09" FINE: 32 1.26"	ULTRA: 130 5.12" SUPER: 81 3.19" TURBO: 50 1.97" HSP: 18 0.71"	FU-31 Approx. 5 g							
								1 m 3.28' Free-cut (ø2.2 ø0.09" x 2) -40 to +70°C ø0.19" ø4.8 -40 to +158°F ø2.1 ø2.1"	R25 R0.98"	MEGA: 320 12.60" FINE: 45 1.77"	ULTRA: 250 9.84" SUPER: 140 5.51" TURBO: 90 3.54" HSP: 32 1.26"	FU-33 Approx. 10 g		
	50 cm 1.64' cut not allowed -40 to +70°C ø0.03" ø0.82 -40 to +158°F ø0.03" ø0.82 ø0.3"	R4 R0.16"	MEGA: 68 2.68" FINE: 18 0.71"	ULTRA: 54 2.13" SUPER: 40 1.57" TURBO: 27 1.06" HSP: 8 0.32"	FU-65X Approx. 5 g									
						2 m 6.56' Free-cut (ø1.3 ø0.05" x 2) -40 to +50°C ø0.08" ø2 -40 to +122°F ø2 ø2	R2 R0.08" ToughFlex	MEGA: 290 11.42" FINE: 54 2.13"	ULTRA: 190 7.48" SUPER: 120 4.72" TURBO: 80 3.15" HSP: 23 0.91"	FU-63Z Approx. 10 g				
	2 m 6.56' Free-cut (ø1.3 ø0.05" x 2) -40 to +70°C ø0.07" ø1.65 -40 to +158°F ø1.65 ø0.03"	R25 R0.98"	MEGA: 330 12.99" FINE: 72 2.83"	ULTRA: 230 9.06" SUPER: 150 5.91" TURBO: 100 3.94" HSP: 36 1.42"	FU-63 Approx. 10 g									
						2 m 6.56' Free-cut (ø1.3 ø0.05" x 2) -40 to +70°C ø0.07" ø1.65 -40 to +158°F ø1.65 ø0.03"	R25 R0.98"	MEGA: 330 12.99" FINE: 72 2.83"	ULTRA: 230 9.06" SUPER: 150 5.91" TURBO: 100 3.94" HSP: 36 1.42"	FU-63T Approx. 10 g				
	Top	50 cm 1.64' cut not allowed -40 to +70°C ø0.03" ø0.12" ø3 -40 to +158°F ø0.82 ø0.82"	R4 R0.16"	MEGA: 68 2.68" FINE: 18 0.71"	ULTRA: 54 2.13" SUPER: 40 1.57" TURBO: 27 1.06" HSP: 8 0.32"						FU-45X Approx. 4 g			
						2 m 6.56' Free-cut (ø1.3 ø0.05" x 2) -40 to +70°C ø0.07" ø4 -40 to +158°F ø1.65 ø0.03"	R25 R0.98"	MEGA: 330 12.99" FINE: 72 2.83"	ULTRA: 230 9.06" SUPER: 150 5.91" TURBO: 100 3.94" HSP: 36 1.42"	FU-43 Approx. 8 g				
	1 m 3.28' cut not allowed -40 to +70°C ø0.06" ø1.5 -40 to +158°F ø0.5 ø0.5"	R10 R0.39"	MEGA: 27 1.06" FINE: 4.8 0.19"	ULTRA: 18 0.71" SUPER: 13 0.51" TURBO: 10 0.39" HSP: 2.4 0.09"	FU-46 Approx. 2 g									
						Coaxial, narrow beam 10°	50 cm 1.64' cut not allowed -40 to +70°C ø0.10" ø2.5 -40 to +158°F ø0.07" ø2.5 ø1.77"	R25 R0.98"	MEGA: 72 2.83" FINE: 23 0.91"	ULTRA: 59 2.32" SUPER: 45 1.77" TURBO: 32 1.26" HSP: 12 0.47"	FU-22X Approx. 4 g			







*1 Detecting distance for reflective fibers is based on a standard target: White matte paper.

Small Spot Reflective

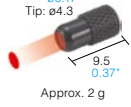
Ideal for detecting small objects.
Select the sensor according to the size of the object.

Parallel Beam Spot

Lens + Fiber Unit

Type	Beam spot diameter (mm inch)	Lens		Fiber units			Detecting distance (mm inch)*	
		Appearance (mm inch) Weight	Model	Minimum bend radius (mm inch)	Appearance	Model	MEGA FINE	Other power modes
Parallel beam	Approx. $\varnothing 4$ $\varnothing 0.16$ " (within the detecting distance of 0 to 20 mm 0 " to 0.79 "*)		F-3HA	R2 R0.08" ToughFlex		FU-35FZ	MEGA: 45 FINE: 1.77"	ULTRA: 45 SUPER: 45 TURBO: 40 HSP: 27
				R10 R0.39" Stainless Steel		FU-35FG	1.42"	45 45 40 27
				R25 R0.98"		FU-35FA	MEGA: 65 FINE: 2.56" 2.13"	65 65 60 45
				R2 R0.08" ToughFlex		FU-35TZ	MEGA: 40 FINE: 1.57" 1.06"	40 40 32 23
				R10 R0.39" Stainless Steel		FU-35TG	1.06"	40 40 32 23



*1 Detecting distance for reflective fibers is based on a standard target: White matte paper.

Small Beam Spot

Lens + Fiber Unit

Type	Beam spot diameter (mm inch)	Focal distance (mm inch)	Lens		Fiber units		
			Appearance (mm inch) Weight	Model	Minimum bend radius (mm inch)	Appearance	Model
Small spot	Approx. $\varnothing 0.1$ $\varnothing 0.004$ "	7 ± 2 0.28 ± 0.08 "		F-2HA	R10 R0.39"		FU-24X
	Approx. $\varnothing 0.2$ $\varnothing 0.008$ "				R25 R0.98"		FU-21X
	Approx. $\varnothing 0.4$ $\varnothing 0.02$ "				R2 R0.08" ToughFlex		FU-35FZ
					R10 R0.39" Stainless Steel		FU-35FG
					R25 R0.98"		FU-35FA
					R2 R0.08" ToughFlex		FU-35TZ
	Approx. $\varnothing 0.5$ $\varnothing 0.02$ "	15 ± 2 0.59 ± 0.08 "		F-4HA	R2 R0.08" ToughFlex		FU-35FZ
					R10 R0.39" Stainless Steel		FU-35FG
					R2 R0.08" ToughFlex		FU-35TZ
					R10 R0.39" Stainless Steel		FU-35TG
					R25 R0.98"		FU-35FA
					R2 R0.08" ToughFlex		FU-21X
Approx. $\varnothing 1.0$ $\varnothing 0.04$ "	35 ± 3 1.38 ± 0.12 "		F-6HA	R25 R0.98"		FU-21X	
Approx. $\varnothing 2.0$ $\varnothing 0.08$ "				R2 R0.08" ToughFlex		FU-35FZ	
				R10 R0.39" Stainless Steel		FU-35FG	
				R2 R0.08" ToughFlex		FU-35TZ	
				R25 R0.98"		FU-35FA	



Built-in Lens Fiber Unit





Type	Beam spot diameter (mm inch)	Focal distance (mm inch)	Fiber unit length (Diameter) Ambient temperature	Appearance (mm inch)	Model Weight	Minimum bend radius (mm inch)
Small spot	Approx. $\varnothing 0.1$ $\varnothing 0.004$ "	5 0.20"	50 cm 1.64 " cut not allowed -40 to +70°C -40 to +158°F		FU-20 Approx. 2 g	R25 R0.98"

Adjustable Beam Spot

Built-in Lens Fiber Unit

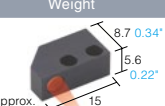
Type	Beam spot diameter (mm inch)	Focal distance (mm inch)	Fiber unit length (Diameter) Ambient temperature	Appearance (mm inch)	Model Weight	Minimum bend radius (mm inch)
Adjustable beam spot	$\varnothing 0.9$ to 3.5 $\varnothing 0.04$ " to 0.14 "	10 to 30 0.39 " to 1.18 "	2 m 6.56 " Free-cut ($\varnothing 1.3$ $\varnothing 0.05$ x 2) -40 to +70°C -40 to +158°F		FU-10 Approx. 5 g	R25 R0.98"

Lens + Fiber Unit

Type	Beam spot diameter (mm inch)	Focal distance (mm inch)	Lens		Fiber units		
			Appearance (mm inch) Weight	Model	Minimum bend radius (mm inch)	Appearance	Model
Side-view adjustable spot	$\varnothing 0.5$ to 3 $\varnothing 0.02$ " to 0.12 "	8 to 30 0.32 " to 1.18 "		F-5HA	R2 R0.08" ToughFlex		FU-35FZ
					R10 R0.39" Stainless Steel		FU-35FG
					R25 R0.98"		FU-35FA



Area

Great for applications where target position varies or for detecting targets with complicated shapes or rough surface finish.

Thrubeam/reflective types

Detecting method	Type		Fiber unit length (Diameter) Ambient temperature	Appearance (mm inch)	Minimum bend radius (mm inch)	Detecting distance (mm inch)**		Optical axis diameter (mm inch)	Model Weight			
	Type	Optical axis width (mm inch)				MEGA FINE	Other power modes					
Thrubeam	Area	10 0.39"	2 m 6.56' Free-cut (ø2.2 ø0.09") -40 to +50°C -40 to +122°F		R2 R0.08" ToughFlex	MEGA: 3400 133.86" FINE: 1400 55.12"	ULTRA: 2800 110.24" SUPER: 2400 94.49" TURBO: 1700 66.93" HSP: 640 25.20"	10x3 0.39"x0.12"	FU-12 Approx. 23 g			
		11 0.43"					MEGA: 3600 141.73" FINE: 2700 106.30"			ULTRA: 3600 141.73" SUPER: 3600 141.73" TURBO: 3600 141.73" HSP: 1300 51.18"		
		40 1.57"					MEGA: 3600 141.73" FINE: 3600 141.73"			ULTRA: 3600 141.73" SUPER: 3600 141.73" TURBO: 3600 141.73" HSP: 2500 98.43"		
	Array	5 0.20"		2 m 6.56' Free-cut (ø2.2 ø0.09") -40 to +70°C -40 to +158°F			R4 R0.16"	MEGA: 2200 86.61" FINE: 440 17.32"	ULTRA: 1400 55.12" SUPER: 840 33.07" TURBO: 540 21.25" HSP: 200 7.87"	Approx. 6 x 0.3 0.24"x0.01"	FU-A05 Approx. 20 g	
		10 0.39"										ULTRA: 1400 55.12" SUPER: 840 33.07" TURBO: 540 21.25" HSP: 200 7.87"
		15 0.59" (at distance 15 0.59")								2 m 6.56' Free-cut (ø2.2 ø0.09" x 2) -40 to +70°C -40 to +158°F		
10 0.39" (at distance 4 0.16")	R4 R0.16"	MEGA: 740 29.13" FINE: 140 5.51"	ULTRA: 460 18.11" SUPER: 260 10.24" TURBO: 180 7.09" HSP: 60 2.36"	-	FU-A05D Approx. 20 g							
15 0.59" (at distance 4 0.16")						R4 R0.16"	MEGA: 740 29.13" FINE: 140 5.51"	ULTRA: 460 18.11" SUPER: 260 10.24" TURBO: 180 7.09" HSP: 60 2.36"	-			FU-A10D Approx. 20 g

*1 Detecting distance for reflective fibers is based on a standard target: White matte paper.

Retro-reflective

Useful for detecting transparent objects.

Retro-reflective type

Detecting method	Type		Fiber unit length (Diameter) Ambient temperature	Appearance (mm inch)	Minimum bend radius (mm inch)	Detecting distance (mm inch)**		Model Weight
	Beam emitting direction					MEGA FINE	Other power modes	
Retro-Reflective	M6		2 m 6.56' Free-cut (ø1.0 ø0.04" x 2) -40 to +50°C -40 to +122°F		R2 R0.08" ToughFlex	MEGA: 10 to 960 0.39" to 37.80" FINE: 10 to 120 0.39" to 4.72"	ULTRA: 10 to 760 0.39" to 29.92" SUPER: 10 to 380 0.39" to 14.96" TURBO: 10 to 230 0.39" to 9.06" HSP: -	FU-13 Approx. 8 g
	Square type						2 m 6.56' Free-cut (ø1.0 ø0.04" x 2) -40 to +50°C -40 to +122°F	

*1 Detecting distance for reflective fibers is based on a standard target: White matte paper.

Reflector/Reflective Tape Specifications (Optional Parts)

Model	Power modes	Detecting distance (mm inch)**			
		R-2 (OP-95388)	R-3 (OP-96436)	R-5	Reflective tape (OP-96629)
FU-13	MEGA	10 to 1880 0.39" to 74.02"	10 to 1540 0.39" to 60.63"	10 to 1060 0.39" to 41.73"	10 to 960 0.39" to 37.80"
	ULTRA	10 to 1500 0.39" to 59.06"	10 to 1240 0.39" to 48.82"	10 to 860 0.39" to 33.86"	10 to 760 0.39" to 29.92"
	SUPER	10 to 760 0.39" to 29.92"	10 to 640 0.39" to 25.20"	10 to 440 0.39" to 17.32"	10 to 380 0.39" to 14.96"
	TURBO	10 to 450 0.39" to 17.72"	10 to 360 0.39" to 14.17"	10 to 230 0.39" to 9.06"	10 to 230 0.39" to 9.06"
	FINE	10 to 250 0.39" to 9.84"	10 to 200 0.39" to 7.87"	10 to 130 0.39" to 5.12"	10 to 120 0.39" to 4.72"
	HSP	-	-	-	-
FU-15**	MEGA	100 to 6400 3.94" to 251.97"	100 to 4400 3.94" to 173.23"	100 to 2600 3.94" to 102.36"	-
	ULTRA	100 to 5000 3.94" to 196.85"	100 to 3600 3.94" to 141.73"	100 to 2200 3.94" to 86.61"	-
	SUPER	100 to 2500 3.94" to 98.43"	100 to 2000 3.94" to 78.74"	100 to 1500 3.94" to 59.06"	-
	TURBO	100 to 1690 3.94" to 66.54"	100 to 1350 3.94" to 53.15"	100 to 1200 3.94" to 47.24"	-
	FINE	100 to 1260 3.94" to 47.61"	100 to 1000 3.94" to 39.37"	100 to 1000 3.94" to 39.37"	-
	HSP	100 to 1000 3.94" to 39.37"	100 to 860 3.94" to 33.86"	100 to 860 3.94" to 33.86"	-

*1 Detecting distance for reflective fibers is based on a standard target: White matte paper.

*2 Reflective tape cannot be used.

Narrow Beam/High-power

Built-in lens reduces beam width and helps reduce stray light.

Thrubeam/reflective types

Detecting method	Type		Fiber unit length (Diameter) Ambient temperature	Appearance (mm inch)	Minimum bend radius (mm inch)	Detecting distance (mm inch)**1		Optical axis diameter (mm inch) (Standard target to be detected)	Model Weight
	Beam emitting direction	Aperture angle				MEGA FINE	Other power modes		
Thrubeam	Side	Approx. 6°	2 m 6.56' Free-cut (ø1.0 ø0.04') FU-16Z: -40 to +50°C -40 to +122°F FU-16/18: -40 to +70°C -40 to +158°F		R2 R0.08" ToughFlex	MEGA: 3600 141.73" FINE: 1260 49.61"	ULTRA: 3600 141.73" SUPER: 2600 102.36" TURBO: 1800 70.87" HSP: 760 29.92"	ø2.5 ø0.10"	FU-16Z Approx. 8 g
		Approx. 2°			R10 R0.39"	MEGA: 3600 141.73" FINE: 1900 74.80"	ULTRA: 3600 141.73" SUPER: 3600 141.73" TURBO: 2700 106.30" HSP: 1000 39.37"		FU-16 Approx. 8 g
		Approx. 3°				MEGA: 3600 141.73" FINE: 1600 62.99"	ULTRA: 3600 141.73" SUPER: 3000 118.11" TURBO: 2100 92.68" HSP: 960 37.80"		FU-18 Approx. 8 g
	Top	Approx. 6°	2 m 6.56' Free-cut (ø1.0 ø0.04') -40 to +50°C 0.16" -40 to +122°F 4"		R2 R0.08" ToughFlex	MEGA: 3600 141.73" FINE: 3600 141.73"	ULTRA: 3600 141.73" SUPER: 3600 141.73" TURBO: 3600 141.73" HSP: 2400 94.49"	ø2.8 ø0.11"	FU-50 Approx. 8 g
Reflective	Top	Approx. 8°	2 m 6.56' Free-cut (ø2.2 ø0.09" x 2) -40 to +50°C -40 to +122°F Thickness: 5.2 0.20"		R2 R0.08" ToughFlex	MEGA: 30 to 2300 FINE: 30 to 290	ULTRA: 30 to 1600 SUPER: 680 TURBO: 30 to 410 HSP: 210	-	FU-40 Approx. 23 g
			1 m 3.28' cut not allowed -40 to +50°C -40 to +122°F Thickness: 5.2 0.20"		R10 R0.39" Stainless Steel	MEGA: 30 to 2300 FINE: 1.18" to 90.55" TURBO: 30 to 290 HSP: 1.18" to 11.42"	ULTRA: 30 to 1600 SUPER: 680 TURBO: 30 to 410 HSP: 1.18" to 16.14" 1.18" to 6.30"		FU-40G Approx. 50 g

*1 3600 mm 141.73" is assumed as maximum because the fiber cable has a length of 2 m 6.56'.
Detecting distance for reflective fibers is based on a standard target: White matte paper.

Definite-reflective

Helps reduce the effect of target background.
The thin, small design requires less space.

Definite-reflective types

Detecting method	Type		Fiber unit length (Diameter) Ambient temperature	Appearance (mm inch)	Minimum bend radius (mm inch)	Detecting distance (mm inch)**1		Beam spot diameter (mm inch)	Model Weight
	Beam emitting direction	Aperture angle				MEGA FINE	Other power modes		
Definite-reflective	Side	Approx. 6°	2 m 6.56' Free-cut (ø1.0 ø0.04" x 2) -40 to +70°C -40 to +158°F Thickness: 5 0.20"		R10 R0.39"	MEGA: 3 (0.12") center of detecting distance FINE: 3 (0.12") center of detecting distance	ULTRA: 3 (0.12") center of detecting distance SUPER: 3 (0.12") center of detecting distance TURBO: 3 (0.12") center of detecting distance HSP: 3 (0.12") center of detecting distance	Approx. ø4.5 ø0.18 ø3.5 ø0.14 (at distance of 3 0.12")	FU-37 Approx. 6 g
		Approx. 2°				MEGA: 6 (0.24") center of detecting distance FINE: 6 (0.24") center of detecting distance	ULTRA: 6 (0.24") center of detecting distance SUPER: 6 (0.24") center of detecting distance TURBO: 6 (0.24") center of detecting distance HSP: 6 (0.24") center of detecting distance	Approx. ø1.5 ø0.06" (at distance of 6 0.24")	FU-38 Approx. 5 g
	Top	Approx. 6°	2 m 6.56' Free-cut (ø1.0 ø0.04" x 2) -40 to +70°C -40 to +158°F Thickness: 4 0.16"				MEGA: 0 to 4 0" to 0.16" FINE: 0 to 4 0" to 0.16"	ULTRA: 0 to 4 0" to 0.16" SUPER: 0 to 4 0" to 0.16" TURBO: 0 to 4 0" to 0.16" HSP: 2±1.4 0.08"±0.06"	-

*1 Detecting distance for reflective fibers is based on a standard target: White matte paper.

High-flex

Provides higher flexibility than electric wire.
R2 (R0.08") types are resistant to repeated bends up to 10 million bends.

Thrubeam/reflective types

Detecting method	Type		Fiber unit length (Diameter) Ambient temperature	Appearance (mm inch)	Minimum bend radius (mm inch)	Detecting distance (mm inch)*1		Optical axis diameter (mm inch) (Standard target to be detected)	Model Weight		
	Size (mm inch)					MEGA FINE	Other power modes				
Thrubeam	M3	ø1.5 ø0.06"	1 m 3.28' Free-cut (ø1.0 ø0.04") -40 to +70°C -40 to +158°F		R4 R0.16" High-flex	MEGA: 1200 47.24" FINE: 230 9.06"	ULTRA: 810 31.89" SUPER: 590 23.23" TURBO: 410 16.14" HSP: 130 5.12"	ø0.7 ø0.03"	FU-59 Approx. 3 g		
		6x10.5x2.5 0.24"x0.41"x0.10"	1 m 3.28' Free-cut (ø1.0 ø0.04") -40 to +70°C -40 to +158°F						FU-79 Approx. 6 g		
		ø1.0 ø0.04"	1 m 3.28' Free-cut (ø1.0 ø0.04") -40 to +50°C -40 to +122°F						FU-57TE Approx. 5 g		
	M4 Built-in lens	ø1.5 ø0.06"	1 m 3.28' Free-cut (ø1.0 ø0.04") -40 to +70°C -40 to +122°F			R2 R0.08" ToughFlex High-flex	MEGA: 590 23.23" FINE: 140 5.51"		ULTRA: 430 16.93" SUPER: 300 11.81" TURBO: 180 7.09" HSP: 55 2.17"	ø0.5 ø0.02"	FU-58U Approx. 4 g
		M3	1 m 3.28' Free-cut (ø1.0 ø0.04") -40 to +50°C -40 to +122°F								FU-59U Approx. 4 g
		M4	1 m 3.28' Free-cut (ø1.0 ø0.04") -40 to +50°C -40 to +122°F								FU-79U Approx. 4 g
		M4 Built-in lens	1 m 3.28' Free-cut (ø1.0 ø0.04") -40 to +50°C -40 to +122°F								FU-70U Approx. 5 g
Reflective	M3	ø1.5 ø0.06"	1 m 3.28' cut not allowed -40 to +70°C -40 to +158°F		R4 R0.16" High-flex	MEGA: 150 5.91" FINE: 32 1.26"	ULTRA: 100 3.94" SUPER: 80 3.15" TURBO: 54 2.13" HSP: 22 0.87"	-	FU-49X Approx. 3 g		
		ø3 ø0.12"	2 m 6.56' Free-cut (ø1.0 ø0.04" x 2) -40 to +70°C -40 to +158°F						FU-69X Approx. 3 g		
		M4	2 m 6.56' Free-cut (ø1.0 ø0.04" x 2) -40 to +70°C -40 to +158°F						FU-48 Approx. 7 g		
	M3	ø2 ø0.08"	1 m 3.28' Free-cut (ø1.0 ø0.04" x 2) -40 to +50°C -40 to +122°F			R2 R0.08" ToughFlex High-flex	MEGA: 290 11.42" FINE: 63 2.48"		ULTRA: 200 7.87" SUPER: 130 5.12" TURBO: 80 3.15" HSP: 32 1.26"	-	FU-68 Approx. 8 g
		ø3 ø0.12"	1 m 3.28' Free-cut (ø1.0 ø0.04" x 2) -40 to +50°C -40 to +122°F								FU-49U Approx. 4 g
		M3	1 m 3.28' Free-cut (ø1.0 ø0.04" x 2) -40 to +50°C -40 to +122°F								FU-48U Approx. 4 g
		M3	1 m 3.28' Free-cut (ø1.0 ø0.04" x 2) -40 to +50°C -40 to +122°F								FU-69U Approx. 4 g

*1 Detecting distance for reflective fibers is based on a standard target: White matte paper.

Oil/Chemical Resistant

PTFE coating allows for use in almost any environment.

Thrubeam/Reflective types

Detecting method	Type		Fiber unit length (Diameter) Ambient temperature	Appearance (mm inch)	Minimum bend radius (mm inch)	Detecting distance (mm inch)*1		Optical axis diameter (mm inch) (Standard target to be detected)	Model Weight
	Beam emitting direction	Size (mm inch)				MEGA FINE	Other power modes		
Thrubeam	Top	ø5 ø0.20"	2 m 6.56' Free-cut (ø2.2 ø0.09") -40 to +70°C -40 to +158°F		R40 R1.57"	MEGA: 3600 141.73" FINE: 2800 110.24"	ULTRA: 3600 141.73" SUPER: 3600 141.73" TURBO: 3600 141.73" HSP: 1400 55.12"	ø3.7 ø0.15"	FU-92 Approx. 71 g
	Side	ø5 ø0.20"	2 m 6.56' Free-cut (ø2.2 ø0.09") -40 to +70°C -40 to +158°F						FU-96 Approx. 71 g
Reflective	Top	ø4.5 ø0.18"	2 m 6.56' Free-cut (ø1.3 ø0.05" x 2) -40 to +70°C -40 to +158°F		R40 R1.57"	MEGA: 310 12.20" FINE: 140 5.51"	ULTRA: 290 11.42" SUPER: 250 9.84" TURBO: 200 7.87" HSP: 80 3.15"	-	FU-91 Approx. 32 g



*1 3600 mm 141.73" is assumed as maximum because the fiber cable has a length of 2 m 6.56'. Detecting distance for reflective fibers is based on a standard target: White matte paper.

Heat Resistant

Resists temperatures up to 350°C (662°F).

A wide variety of heat-resistant types are available, including the easy-to-install R5(R0.20") type and the high-temperature type, resistant to temperatures up to 350°C (662°F). Fibers used in sensors resistant to temperatures of 200°C (392°F) or more are made from multi-component glass.

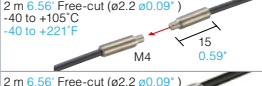
Thrubeam/reflective types

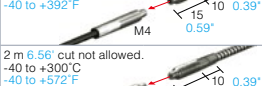
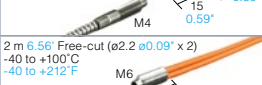
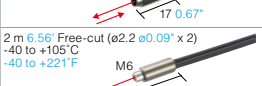
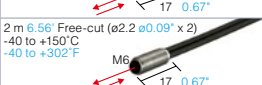
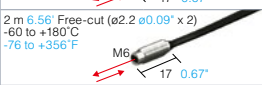
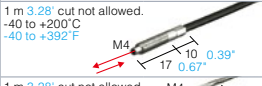
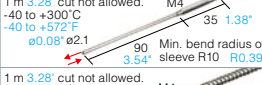
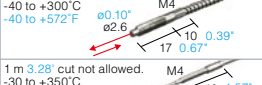
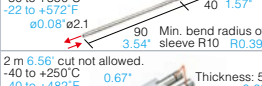
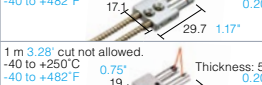
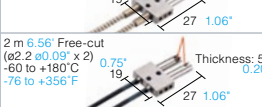
Detecting method	Type	Fiber unit length (Diameter) Ambient temperature	Appearance (mm inch)	Minimum bend radius (mm inch)	Detecting distance (mm inch)*1		Optical axis diameter (mm inch) (Standard target to be detected)	Model Weight	
					MEGA FINE	Other power modes			
Thrubeam	100°C 212°F ^{4,3}	2 m 6.56 Free-cut (ø2.2 ø0.09") -40 to +100°C -40 to +212°F		R5 R0.20" ToughFlex	MEGA: 3600 FINE: 680	141.73" 26.77"	ULTRA: 2200 SUPER: 1600 TURBO: 900 HSP: 390	86.61" 62.99" 35.43" 15.35"	FU-86Z Approx. 25 g
	105°C 221°F ^{4,3}	2 m 6.56 Free-cut (ø2.2 ø0.09") -40 to +105°C -40 to +221°F		R25 R0.98"	MEGA: 3600 FINE: 1100	141.73" 43.31"	ULTRA: 3200 SUPER: 2200 TURBO: 1500 HSP: 540	125.98" 86.61" 59.06" 21.26"	FU-86A Approx. 22 g
	150°C 302°F ^{4,4}	2 m 6.56 Free-cut (ø2.2 ø0.09") -40 to +150°C -40 to +302°F		R20 R0.79"	MEGA: 2700 FINE: 520	106.30" 20.47"	ULTRA: 1800 SUPER: 1100 TURBO: 720 HSP: 340	70.87" 43.31" 28.35" 13.39"	FU-86H Approx. 35 g
	180°C 356°F ^{4,5}	2 m 6.56 Free-cut (ø2.2 ø0.09") -60 to +180°C -76 to +356°F		R35 R1.38"	MEGA: 2700 FINE: 570	106.30" 22.44"	ULTRA: 1900 SUPER: 1200 TURBO: 790 HSP: 380	74.80" 47.24" 31.10" 14.96"	FU-88 Approx. 36 g
	200°C 392°F	2 m 6.56 cut not allowed. -40 to +200°C -40 to +392°F		R8 R0.32"	MEGA: 1800 FINE: 390	70.87" 15.35"	ULTRA: 1300 SUPER: 900 TURBO: 680 HSP: 250	51.18" 35.43" 26.77" 9.84"	FU-88K Approx. 30 g
	300°C 572°F	2 m 6.56 cut not allowed. -40 to +300°C -40 to +572°F		R25 R0.98"	Lens attachment: P14				FU-84C Approx. 66 g
Reflective	100°C 212°F ^{4,3}	2 m 6.56 Free-cut (ø2.2 ø0.09" x 2) -40 to +100°C -40 to +212°F		R5 R0.20" ToughFlex	MEGA: 740 FINE: 160	29.13" 6.30"	ULTRA: 580 SUPER: 410 TURBO: 320 HSP: 90	22.83" 16.14" 12.60" 3.54"	FU-85Z Approx. 25 g
	105°C 221°F ^{4,3}	2 m 6.56 Free-cut (ø2.2 ø0.09" x 2) -40 to +105°C -40 to +221°F		R25 R0.98"	MEGA: 1100 FINE: 230	43.31" 9.06"	ULTRA: 860 SUPER: 590 TURBO: 410 HSP: 140	33.86" 23.23" 16.14" 5.51"	FU-85A Approx. 21 g
	150°C 302°F ^{4,4}	2 m 6.56 Free-cut (ø2.2 ø0.09" x 2) -40 to +150°C -40 to +302°F		R20 R0.79"	MEGA: 720 FINE: 160	28.35" 6.30"	ULTRA: 560 SUPER: 410 TURBO: 320 HSP: 90	22.05" 16.14" 12.60" 3.54"	FU-85H Approx. 35 g
	180°C 356°F ^{4,5}	2 m 6.56 Free-cut (ø2.2 ø0.09" x 2) -60 to +180°C -76 to +356°F		R35 R1.38"	MEGA: 860 FINE: 200	33.86" 7.87"	ULTRA: 710 SUPER: 470 TURBO: 350 HSP: 100	27.95" 18.50" 13.78" 3.94"	FU-87 Approx. 33 g
	200°C 392°F	1 m 3.28 cut not allowed. -40 to +200°C -40 to +392°F		R8 R0.32"					FU-87K Approx. 15 g
	300°C 572°F	1 m 3.28 cut not allowed. -40 to +300°C -40 to +572°F		R25 R0.98"	MEGA: 770 FINE: 190	30.32" 7.48"	ULTRA: 650 SUPER: 450 TURBO: 340 HSP: 100	25.59" 17.72" 13.38" 3.94"	FU-82C Approx. 29 g
	350°C 662°F	1 m 3.28 cut not allowed. -30 to +350°C -22 to +662°F		R25 R0.98"	MEGA: 650 FINE: 140	25.59" 5.51"	ULTRA: 560 SUPER: 390 TURBO: 290 HSP: 86	22.05" 15.35" 11.42" 3.39"	FU-81C Approx. 24 g
	250°C 482°F	2 m 6.56 cut not allowed. -40 to +250°C -40 to +482°F		R25 R0.98"	MEGA: 8 to 37 FINE: 8 to 30	0.32" to 1.46" 0.32" to 1.18"	ULTRA: 8 to 34 SUPER: 8 to 32 TURBO: 8 to 30 HSP: 10 to 18	0.32" to 1.34" 0.32" to 1.26" 0.32" to 1.18" 0.39" to 0.71"	FU-38LK Approx. 70 g
	180°C 356°F	2 m 6.56 Free-cut (ø2.2 ø0.09" x 2) -60 to +180°C -76 to +356°F		R35 R1.38"	MEGA: 2.5 to 65 FINE: 2.5 to 16	0.10" to 2.56" 0.10" to 0.63"	ULTRA: 2.5 to 55 SUPER: 2.5 to 27 TURBO: 2.5 to 22 HSP: 2.5 to 10	0.10" to 2.17" 0.10" to 1.06" 0.10" to 0.87" 0.10" to 0.39"	FU-38K Approx. 45 g

*1 Detecting distance for reflective fibers is based on a standard target: White matte paper. (For the FU-38LK, the distances are based on a glass substrate (t = 0.7 mm 0.03") detected in the planar direction.)

*2 Use the fiber sensor under dry conditions. Allow some margin for the temperature upper limit when selecting a heat-resistant fiber unit.

*3 The recommended maximum ambient temperature during operation is 90°C 194°F when constantly using a fiber unit in a high-temperature environment.

*4 The recommended maximum ambient temperature during operation is 130°C 266°F when constantly using a fiber unit in a high-temperature environment.

*5 The recommended maximum ambient temperature during operation is 150°C 302°F when constantly using a fiber unit in a high-temperature environment.

Liquid-level

Liquid-level detection sensors.
Available in tube-mountable and immersible types.

Reflective

Detecting method	Type		Fiber unit length (Diameter) Ambient temperature	Appearance (mm inch)	Minimum bend radius (mm inch)	Accessory	Model Weight
	Transparent tube diameter (mm inch)	Beam axis					
Tube-mountable type	ø4 to 26 ø0.16" to 1.02"	16	2 m 6.56" Free-cut (ø2.2 ø0.09" x 2) -40 to +70°C -40 to +158°F		R5 R0.20"	Binding band x 2 Nonslip rubber x 2	FU-95S Approx. 23 g
		1	2 m 6.56" Free-cut (ø1.0 ø0.04" x 2) FU-95Z: -40 to +50°C -40 to +122°F FU-95HA: -40 to +105°C -40 to +221°F FU-95: -40 to +70°C -40 to +158°F		R2 R0.08" ToughFlex	Binding band x 2 Nonslip rubber x 2 Spacer x 2 Screw x 2 Nut x 2	FU-95Z Approx. 7 g
			R25 R0.98"	FU-95HA Approx. 7 g			
	R10 R0.39"	FU-95 Approx. 7 g					
	ø26 ø1.02" or more recommended	16	2 m 6.56" Free-cut (ø2.2 ø0.09" x 2) -40 to +70°C -40 to +158°F		R5 R0.20"	None (Optionally available)	FU-95W Approx. 20 g

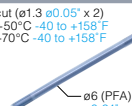
Detecting method	Type	Fiber unit length (Diameter) Ambient temperature	Appearance (mm inch)	Minimum bend radius (mm inch)		Model Weight
				PFA-sheathed section	Fiber	
Immersion		2 m 6.56" Free-cut (ø1.3 ø0.05" x 2) FU-93Z: -40 to +50°C -40 to +158°F FU-93 : -40 to +70°C -40 to +158°F		R40 R1.57"	R0.5 R0.02" ToughFlex	FU-93Z Approx. 78 g
					R25 R0.98"	FU-93 Approx. 78 g

* Not bendable up to 80 mm (3.15") from the tip.

Liquid Crystal/Semiconductors

Perfect for detecting glass substrates.
Lineup offers distance alignment, edge detection, and wafer mapping types.

Thrubeam

Application	Type		Fiber unit length (Diameter) Ambient temperature	Appearance (mm inch)	Minimum bend radius (mm)	Detecting distance (mm inch)**		Optical axis diameter (mm inch) (Standard target to be detected)	Model Weight
	Beam emitting direction	Aperture angle				MEGA FINE	Other power modes		
Mapping	Side	Approx. 3°	2 m 6.56" Free-cut (ø1.0 ø0.04") -40 to +70°C -40 to +158°F		R10 R0.39"	MEGA: 1300 51.18" FINE: 330 12.99"	ULTRA: 900 35.43" SUPER: 680 26.77" TURBO: 530 20.87" HSP: 210 8.27"	ø1 ø0.04"	FU-18M Approx. 6 g

Reflective

Application	Type		Fiber unit length (Diameter) Ambient temperature	Appearance (mm inch)	Minimum bend radius (mm inch)	Detecting distance (mm inch)**		Model Weight
	Beam emitting direction	Heat resistant**2 temperatures				MEGA FINE	Other power modes	
Glass substrate mapping	Top		2 m 6.56" Free-cut (ø2.2 ø0.09" x 2) -40 to +70°C -40 to +158°F		R25 R0.98"	MEGA: 15 to 70 FINE: 15 to 30	ULTRA: 15 to 60 SUPER: 15 to 46 TURBO: 15 to 38 HSP: -	FU-40S Approx. 25 g
Glass substrate alignment	Flat		2 m 6.56" Free-cut (ø2.2 ø0.09" x 2) -40 to +70°C -40 to +158°F		R5 R0.20"	MEGA: 0 to 25 FINE: 0 to 25	ULTRA: 8 to 36 SUPER: 8 to 35 TURBO: 8 to 34 HSP: 10 to 26	FU-38L Approx. 20 g
Seating check			2 m 6.56" Free-cut (ø1.0 ø0.04" x 2) -40 to +70°C -40 to +158°F		R25 R0.98"	MEGA: 0 to 14 FINE: 0 to 14	ULTRA: 0 to 14 SUPER: 0 to 14 TURBO: 0 to 14 HSP: 0 to 12	FU-38R Approx. 20 g
Heat-resistant glass substrate alignment	Flat	250°C 482°F	2 m 6.56" Free-cut not allowed. -40 to +250°C -40 to +482°F		R25 R0.98"	MEGA: 8 to 37 FINE: 8 to 30	ULTRA: 8 to 34 SUPER: 8 to 32 TURBO: 8 to 30 HSP: 10 to 18	FU-38LK Approx. 70 g
Heat-resistant seating, presence check		180°C 356°F*3	2 m 6.56" Free-cut (ø2.2 ø0.09" x 2) -40 to +180°C -40 to +356°F		R35 R1.38"	MEGA: 0 to 4 FINE: 0 to 4	ULTRA: 0 to 4 SUPER: 0 to 4 TURBO: 0 to 4 HSP: 2±1.4	FU-38V Approx. 5 g
			1 m 3.28" cut not allowed. -40 to +250°C -40 to +482°F			MEGA: 2.5 to 65 FINE: 2.5 to 16	ULTRA: 2.5 to 55 SUPER: 2.5 to 27 TURBO: 2.5 to 22 HSP: 2.5 to 10	FU-38K Approx. 45 g
			2 m 6.56" Free-cut (ø2.2 ø0.09" x 2) -40 to +180°C -40 to +356°F			MEGA: 2.5 to 65 FINE: 2.5 to 16	ULTRA: 2.5 to 55 SUPER: 2.5 to 27 TURBO: 2.5 to 22 HSP: 2.5 to 10	FU-38H Approx. 45 g

*1 Detecting distance for reflective fibers is based on a standard target: White matte paper. (For the FU-38LK, the distances are based on a glass substrate (t = 0.7 mm 0.03") detected in the planar direction.)

*2 Use the fiber sensor under dry conditions. Allow some margin for the temperature upper limit when selecting a heat-resistant fiber unit.

*3 The recommended maximum ambient temperature during operation is 150°C 302°F when constantly using a fiber unit in a high-temperature environment.

Specifications

Type		Standard 1 output				High functionality 2 output				Monitor output	O-line
		Cable		M8 connector*1		Cable		M8 connector*1		Cable	-
Model	NPN	FS-N11N	FS-N12N	FS-N11CN	FS-N12CN	FS-N13N	FS-N14N	-	-	FS-N11MN	FS-N10
	PNP	FS-N11P	FS-N12P	FS-N11CP	FS-N12CP	FS-N13P	FS-N14P	FS-N13CP	FS-N14CP	-	FS-N10
Main unit/Expansion unit		Main unit	Expansion unit	Main unit	Expansion unit	Main unit	Expansion unit	Main unit	Expansion unit	Main unit	Expansion unit (No output cable)
Control output		1	1	1	1	2	2	2	2	1	N/A*2
Monitor output (1-5 V)		-	-	-	-	-	-	-	-	1	-
External input		-	-	1	1	1	1	-	-	-	-
Response time		50 μs (HIGH SPEED)/250 μs (FINE)/500 μs (TURBO)/1 ms (SUPER)/4 ms (ULTRA)/16 ms (MEGA)									
Control output	NPN output	NPN open collector 24 V; 1 output max: 100 mA or less; 2 output total: 100 mA or less (used stand-alone)/20 mA or less (multiple connections); residual voltage 1 V or less									
	PNP output	PNP open collector 24 V; 1 output max: 100 mA or less; 2 output total: 100 mA or less (used stand-alone)/20 mA or less (multiple connections); residual voltage 1 V or less									
Monitor output*3		1 to 5 V voltage output; load resistance 10 kΩ or more; repeat precision ±0.5% of F.S.; 1 ms response time (HIGH SPEED, FINE, TURBO)*4									
External input		Input time 2 ms (ON)/20 ms (OFF) or more (25 ms or more (ON/OFF) when external calibration is selected.)									
Multiple connections to Expansion units		Up to 16 units can be connected total (two output type is treated as two units)									
Light source		Red, 4-element LED									
APC		ON/OFF switchable (Factory setting: OFF)									
Number of interference prevention units		0 for HIGH SPEED; 4 for FINE; 8 for TURBO/SUPER/ULTRA/MEGA (When set to double, the number of interference-prevention units will be doubled.)									
Rating	Power voltage	12 - 24 V DC ±10% ripple (P-P) 10% or less									
	NPN Amplifier Current Consumption	Normal: 900 mW or less (36 mA max. at 24 V, 48 mA max. at 12 V)*5 Eco on mode: 800 mW or less (32 mA max. at 24 V, 39 mA max. at 12 V)*5 Eco Full mode: 470 mW or less (19 mA max. at 24 V, 23 mA max. at 12 V)									
	PNP Amplifier Current Consumption	Normal: 950 mW or less (39 mA max. at 24 V, 52 mA max. at 12 V)*5 Eco on mode: 850 mW or less (35 mA max. at 24 V, 44 mA max. at 12 V)*5 Eco Full mode: 520 mW or less (21 mA max. at 24 V, 26 mA max. at 12 V)	Normal: 1050 mW or less (42 mA max. at 24 V, 56 mA max. at 12 V)*5 Eco on mode: 950 mW or less (38 mA max. at 24 V, 47 mA max. at 12 V)*5 Eco Full mode: 600 mW or less (24 mA max. at 24 V, 29 mA max. at 12 V)								
Environmental resistance	Operating ambient luminance	Incandescent lamp: 20000 lux or less; Sunlight: 30000 lux or less									
	Operating ambient temperature	-20 to +55 °C -4 to +131 °F (no freezing)*6									
	Operating ambient humidity	35 to 85% RH (no condensation)									
	Vibration resistance	10 to 55 Hz Compound amplitude 1.5 mm 0.06", 2 hours for each of X,Y,Z axis									
	Shock resistance	500 m/s ² 3 times for each of X,Y,Z axis									
Case material		Both main unit and expansion unit housing material: Polycarbonate									
Weight		Approx. 75 g	Approx. 45 g	Approx. 22 g	Approx. 22 g	Approx. 80 g	Approx. 70 g	Approx. 22 g	Approx. 22 g	Approx. 75 g	Approx. 20 g

*1 Use a cable length of 30m (98.43') or less for M8 connector types.

*2 Counted as 1 output when connecting with the network unit NU Series.

*3 FS-N11MN only

*4 SUPER: 1.2 ms, ULTRA: 1.8 ms, MEGA: 4.2 ms

*5 Increases 100 mW (4.0 mA) for High Speed mode

*6 One or two more units connected: -20 to +55°C (-4 to +131°F); 3 to 10 more units connected: -20 to +50°C (-4 to +122°F); 11 to 16 more units connected: -20 to +45°C (-4 to +113°F).
When using 2-outputs, one unit is counted as two units. All temperature regulations are for when the unit is mounted on a DIN rail and installed on metal sheeting.

EtherNet/IP Compatible Network Unit: NU-EP1

Model		NU-EP1
Ethernet specifications	Compliant standards	IEEE802.3 (10BASE-T)
		IEEE802.3u (100BASE-TX)
	Transmission rate	IEEE802.3af (Power over Ethernet, Class 3)
		10 Mbps (10BASE-T) 100 Mbps (100BASE-TX)
	Transmission medium	STP cable or Category 3 or higher UTP cable (10BASE-T) ¹ STP cable or Category 5 or higher UTP cable (100BASE-TX)
	Maximum cable length	100 m 328.1' (Distance between NU-EP1 and Ethernet switch)
Maximum number of connectable hubs ²	4 (10BASE-T) ² (100BASE-TX)	
EtherNet/IP	Compatible functions	Cyclic communication Compatible with UCMM and Class 3 messaging (Explicit messaging)
	Number of connections	64
	RPI (Transmission cycle)	0.5 to 10000 ms (in 0.5 ms)
	Tolerable communication bandwidth for cyclic communication	6000 pps
	Message communication	Compatible with UCMM and Class 3
Sensor connection specifications	Conformance test	Compatible with Version A7
	Connectable sensors	Sensor amplifiers with N-bus support ³
	Number of connectable sensor units	Up to 16 units ⁴
	Power supply	Power is supplied from the NU-EP1 via wire-saving connector.
	Allowable passing current ⁵	Overall 1200 mA or less
	Power during PoE power receiving ⁶	Supply voltage: 24 V ± 10 %, supply current: 360 mA or less ⁷
Indicator lamps		Link/activity indicator (LINK/ACT): Green LED
		Module status indicator (MS): 2-color (green/red) LED
		Network status indicator (NS): 2-color (green/red) LED
		Sensor communication indicator (D-bus): 2-color (green/red) LED
Power voltage		24 VDC ± 10%, ripple (p-p) 10% or less, (with power supply connector) 48 VDC (Max: 57 VDC) (During PoE power receiving)
Power consumption		1500 mW or less (at 24 V 60 mA max) ⁸
Environmental resistance	Operating ambient temperature	-20 to 55 °C -4 to 131 °F (no freezing)
	Operating ambient humidity	35 to 85% RH (no condensation)
	Vibration resistance	10 to 55 Hz compound amplitude 1.5 mm 0.06" , 2 hours each in X, Y, Z directions
	Pollution degree	2
Materials		Main unit case: Polycarbonate
		Power supply connector: Polyamide (plug), PBT (socket)
Weight (including connectors)		Approx. 80 g
Accessories		Instruction manual x 1, power connector x 1, end unit x 2

- When using the power PoE power receiving function, use the STP cable or Category 5 or higher UTP cable.
- The number of connectable units is not limited when using a switch.
- "N-bus" is the name of KEYENCE's wiring-saving system for sensor amplifiers.
- Varies with the sensor amplifiers connected.
- Current value which, when supplying power from the power supply connector, can be supplied to the NU-EP1 or to a sensor amplifier unit connected to the NU-EP1.
- Power which can be supplied to the sensor amplifier when using the PoE power receiving function.
- Varies according to the working ambient temperature. (-20 to 45 °C **-4 to 113 °F**: 360 mA or less, 45 to 50 °C **113 to 122 °F**: 260 mA or less, 50 to 55 °C **122 to 131 °F**: 140 mA or less)
- Does not include power supplied to connected sensor amplifier.

EtherCAT Compatible Network Unit: NU-EC1

Model		NU-EC1
Ethernet specifications	Compliant standards	IEEE802.3u (100BASE-TX)
	Transmission speed	100 Mbps (100BASE-TX)
	Transmission interface	Category 5e STP
	Distance between nodes	100 m 328.1'
	Communication port	RJ-45 x2
EtherCAT communication specifications	Compatible functions	Process data object communication (cyclic communication) Mailbox communication (message communication) CoE compatible
	Connectable sensors	Sensor amplifiers with N-bus support ¹
Sensor connection specifications	Number of connectable sensor units	16 units max. ²
	Power supply	Power supplied from the NU-EC1 via wire-saving connector
	Tolerable current ³	Total 1200 mA or less
Indicator lamps		Power indicator (PWR): Green LED
		RUN indicator (RUN): Green LED
		ERR indicator (ERR): Red LED
		Sensor communication indicator (N-bus): 2-color (green/red) LED
Power voltage		Link/activity indicator: Green LED 24 VDC ±10%; ripple (p-p) 10% or less
Power consumption		1700 mW or less (at 24 V, 70 mA max.) ⁴
Environmental resistance	Operating ambient temperature	-20 to +55 °C -4 to 131 °F (no freezing)
	Operating ambient humidity	35 to 85% RH (no condensation)
	Vibration resistance	10 to 55 Hz, compound amplitude 1.5 mm 0.06" , 2 hours each in X, Y, Z directions
	Pollution degree	2
Materials		Main unit case and dust cover: Polycarbonate
		Power supply connector: Polyamide (plug), PBT (socket)
Weight (including connectors)		Approx. 80g

- "N-bus" is the name of KEYENCE's wiring-saving system for sensor amplifiers.
- Varies with the sensor amplifiers connected.
- Value of current supplied to this product or sensor amplifier or module connected to this product.
- Exclusive of the current supplied to the sensor amplifiers connected.
- EtherCAT® is registered trademark and patented technology, licensed by BeckhoffAutomation GmbH, Germany.

DeviceNet Compatible Communication Unit: NU-DN1

Model		NU-DN1		
Communication method		DeviceNet compliant		
DeviceNet specifications	Compliant functions	I/O Message (polling) Explicit Message		
	Address setting	0 to 63 (PGM compatible)		
	Baud rate (automatically switched)	500 kbps	250 kbps	125 kbps
	Maximum cable length	100 m 328.1' (thick cable) 100 m 328.1' (thin cable)	250 m 820.2' (thick cable) 100 m 328.1' (thin cable)	500 m 1640.4' (thick cable) 100 m 328.1' (thin cable)
Sensor connection specifications	Connectable sensors	Sensor amplifiers with N-bus support ¹		
	Number of connectable sensor units	Up to 16 units max. ²		
	Power supply	Power is supplied via the DeviceNet communication power supply via NU-DN1.		
	Allowable passing current	Overall 1200 mA or less ³		
Indicator lamps		Network status indicator: 2-color (green/red) LED, Module status indicator: 2-color (green/red) LED, N-bus indicator: 2-color (green/red) LED		
Power voltage		11 to 25 VDC ⁴		
Power consumption		1480 mW or less (60 mA max. at 24 V, 106 mA max. at 12 V) ⁵		
Environmental resistance	Operating ambient temperature	-20 to +55°C -4 to 131 °F (no freezing)		
	Operating ambient humidity	35 to 85% RH (no condensation)		
	Vibration resistance	10 to 55 Hz, compound amplitude 1.5 mm 0.06" , 2 hours each in X, Y, Z directions		
	Pollution degree	2		
Materials		Main unit case and dust cover: Polycarbonate, DeviceNet connector: Polyamide (plug), PBT (socket)		
Weight (including connectors)		Approx. 65g		

- "N-bus" is the name of KEYENCE's wiring-saving system for sensor amplifiers.
- Depends on the sensor amplifiers connected.
- Indicates the current that can be supplied to this product or to the sensor amplifier units linked to this product.
- Power to the NU-DN1 is supplied from the DeviceNet. communication power supply. The same power is also supplied to all sensor amplifiers connected, via the NU-DN1.
- Exclusive of the current supplied to the sensor amplifiers connected.

CC-Link Compatible Network Unit: NU-CL1

Model		NU-CL1		
Communication method		CC-Link compliant		
CC-Link specifications	Compatible versions	Ver.2.00/Ver.1.10 (selectable)		
	Number of occupied stations	Ver.2.00: 3 stations; Ver.1.10: 1/2/3/4 stations (selectable)		
	Type of station	Remote device station		
	Transmission rate	156 kbps/625 kbps/2.5 Mbps/5 Mbps/10 Mbps		
	Setting of station numbers	1 to 64		
Sensor connection specifications	Connectable sensors	Sensor amplifiers with N-bus support ¹		
	Number of connectable sensor units	16 units max. ²		
	Power supply	Power is supplied from the NU-CL1 via wire-saving connector.		
	Allowable passing current	Overall 1200 mA or less ³		
Indicator lamps		Power indicator: Green LED, Communication indicator (L_RUN): Green LED, Communication error indicator (L_ERR): Red LED, Sensor communication indicator: 2-color (green/red) LED		
Power voltage		24 VDC ± 10%; ripple (p-p) 10% or less		
Power consumption		1400 mW or less (55 mA max. at 24 V) ⁴		
Environmental resistance	Operating ambient temperature	0 to +55°C 32 to 131 °F (no freezing)		
	Operating ambient humidity	35 to 85% RH (no condensation)		
	Vibration resistance	10 to 55 Hz, compound amplitude 1.5 mm 0.06" , 2 hours each in X, Y, Z directions		
	Pollution degree	2		
Materials		Main unit case and dust cover: Polycarbonate CC-Link connector and power supply connector: Polyamide (plug), PBT (socket)		
Weight (including connectors)		Approx. 80g		

- "N-bus" is the name of KEYENCE's wiring-saving system for sensor amplifiers.
- Depends on the sensor amplifiers connected.
- Indicates the current that can be supplied to this product or to the sensor amplifier units linked to this product.
- Exclusive of the current supplied to the sensor amplifiers connected.

e-CON Network Input Unit: NU-EN8N

Model		NU-EN8N	
Connectable communication units		Compatible communication units, NU-DN1/NU-CL1/NU-EP1/NU-EC1	
Number of connectable units		2 units max.(occupied ID numbers: 8) ¹	
I/O	Connector	e-CON connector (4-pin)	
	Inputs	8	
	Supply voltage for equipment	Supplied via the NU-EN8N from the connected communication unit	
	Supply current	520 mA or less (total for eight ports)	
	Input signal	NPN open collector output, contact output	
	Input response time	20 μs or less	
	Internal input voltage	8 VDC (Reference value of input current: 3.1 mA)	
	Minimum ON voltage	6 V	
	Maximum OFF current	0.9 mA	
	Input resistance	2.4 kΩ	
Power voltage		12 to 24 VDC ± 10%; ripple (p-p) 10% or less ²	
Weight (including tag)		Approx. 55g	
Accessories		Instruction manual, Tag, Index seal	

- The NU-EN8N occupies eight ID numbers of the communication unit regardless of the number of input devices connected.
- Power to the NU-EN8N is supplied from the connected communication unit.

Input and Output Circuit Diagrams

FS-N11N / N12N / N11MN / N13N / N14N

Output Circuit Diagram

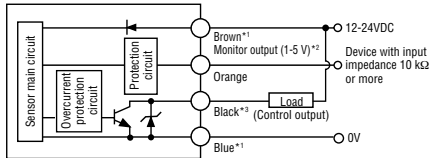

Input Circuit Diagram (FS-N13N/N14N only)

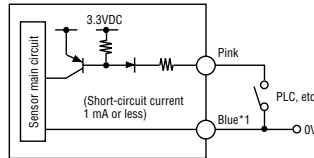

*1 FS-N11N/N11MN/N13N only

*2 FS-N11MN only

*3 The FS-N13N/N14N has a white cable as separate output 2.

FS-N11P / N12P / N13P / N14P / N13CP / N14CP

Output Circuit Diagram

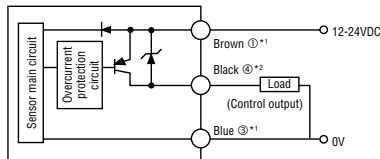

Input Circuit Diagram (FS-N13P/N14P only)

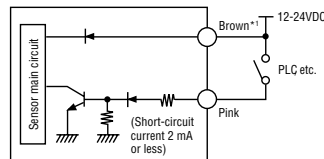

M8 connector pin layout



*1 FS-N11P/N13P/N13CP only

*2 The FS-N13P/N14P has a white cable as separate output. The FS-N13CP/N14CP has pin ② as separate output 2.

FS-N11CN / N12CN

Output Circuit Diagram

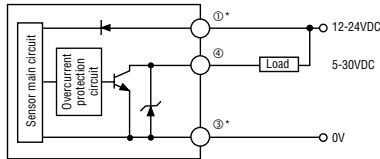

Input Circuit Diagram

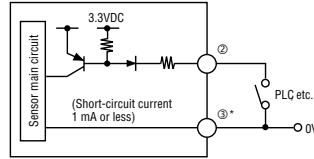

M8 connector pin layout



* FS-N11CN only

FS-N11CP / N12CP

Output Circuit Diagram

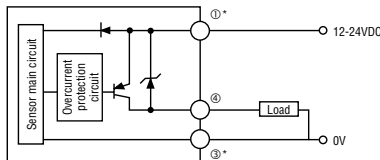

Input Circuit Diagram

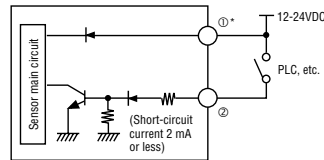

M8 connector pin layout



* FS-N11CP only

Socket Cable (sold separately)

For FS-N11CN / N11CP / N12CN / N12CP / N13CP / N14CP

OP-73864
(Cable length: 2 m [6.56'](#))

OP-73865
(Cable length: 10 m [32.81'](#))

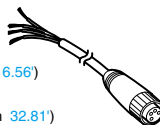

Pin – wire color

Connected pin number	Core wire cover color
①	Brown
②	White
③	Blue
④	Black

Dimensions

Unit: mm inch

FS-N11N / N11P / N13N / N13P / N11MN Main unit (lead wire type)

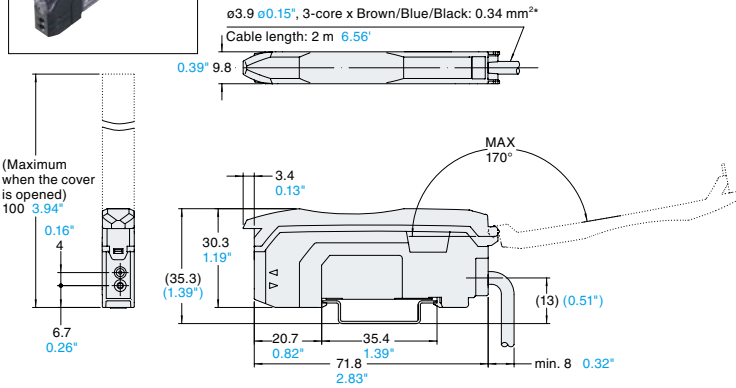

* FS-N11MN: ø3.9 ø0.15, 4-core x Brown/Blue: 0.34 mm² Black/Orange: 0.18 mm²
 FS-N13N/N13P: ø3.9 ø0.15, 5-core x Brown/Blue: 0.34 mm² Black/White/Pink: 0.18 mm²

FS-N12N / N12P / N14N / N14P Expansion unit (lead wire type)

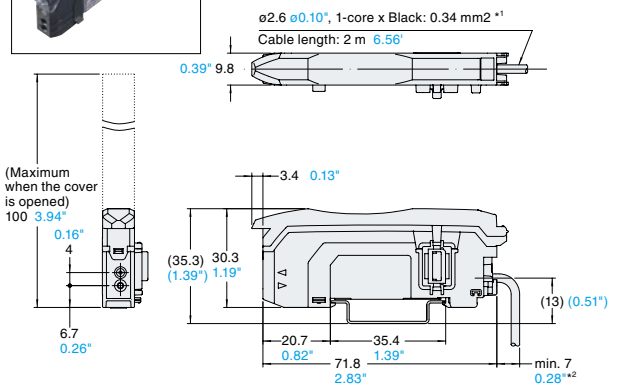

*1 FS-N14N/N14P: ø3.9 ø0.15, 3-core x Black/White/Pink: 0.18 mm²
 *2 FS-N14N/N14P: min. 8 (0.32")

When the mounting bracket is attached (OP-73880 sold separately)

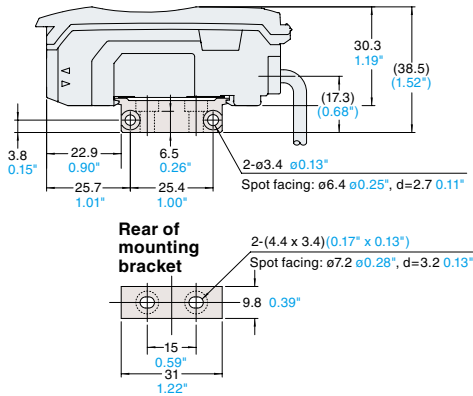

When several units are connected

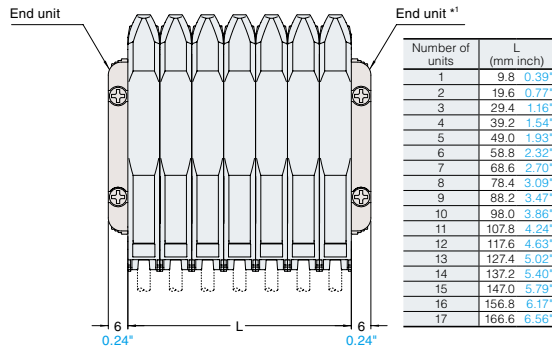

*1 When using expansion units, be sure to use the end unit. (Optional)

End unit (OP-26751 sold separately)

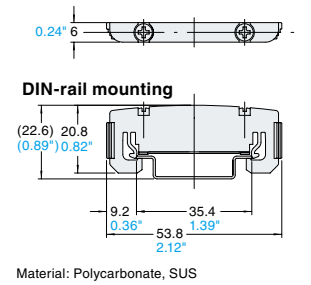

FS-N10

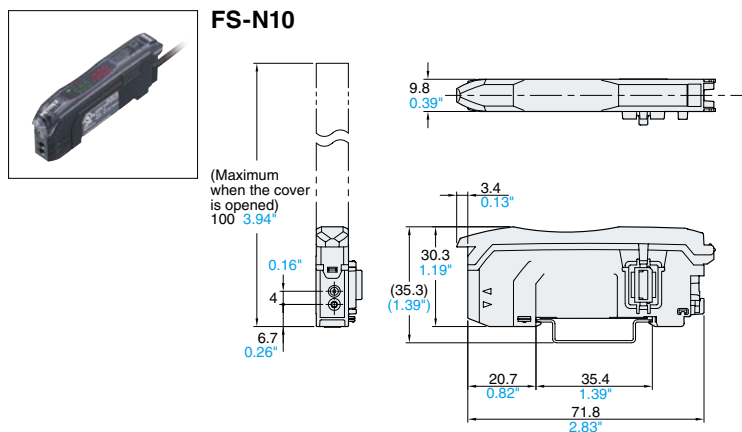

Unit: mm inch

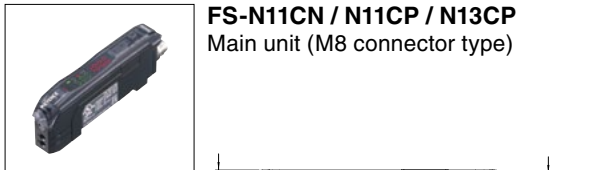

FS-N11CN / N11CP / N13CP
Main unit (M8 connector type)

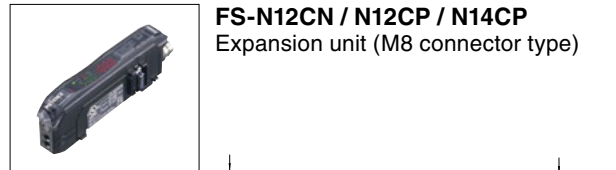
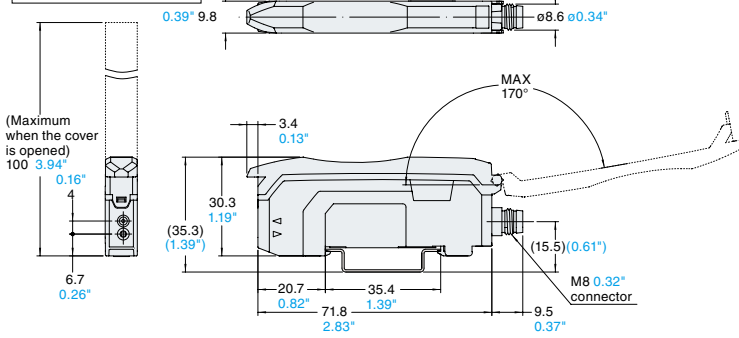

FS-N12CN / N12CP / N14CP
Expansion unit (M8 connector type)

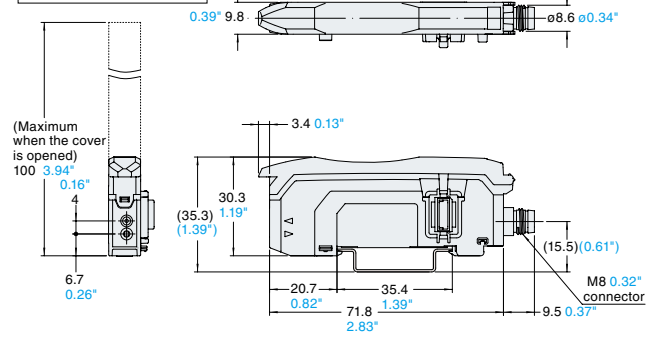

M8 socket cable (separately sold option)

Cable length	L (m foot)
OP-73864	2 6.56'
OP-73865	10 6.56'

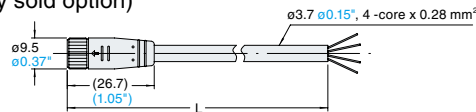

When the mounting bracket is attached (OP-73880 sold separately)

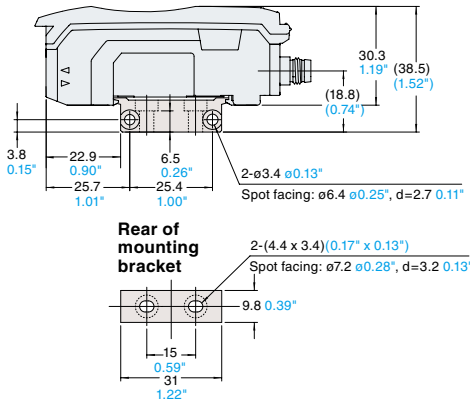

When several units are connected

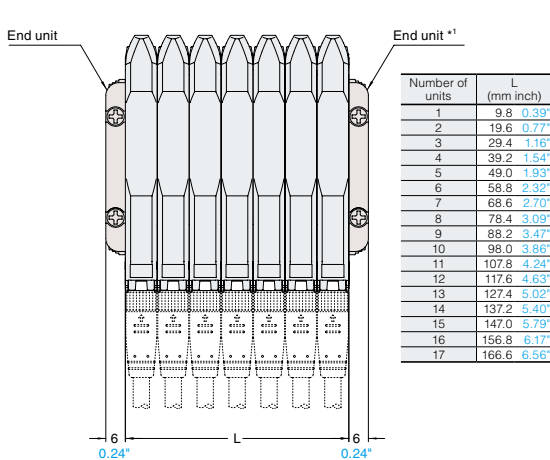

*1 When using expansion units, be sure to use the end unit. (Optional)

OP-87199
Expansion converter unit

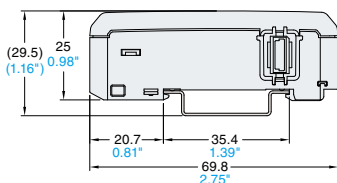
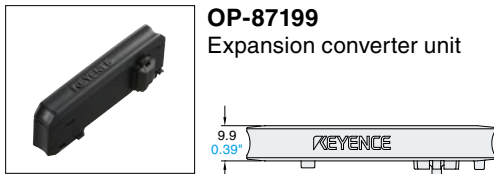

Dimensions

Unit: mm inch

NU-EP1

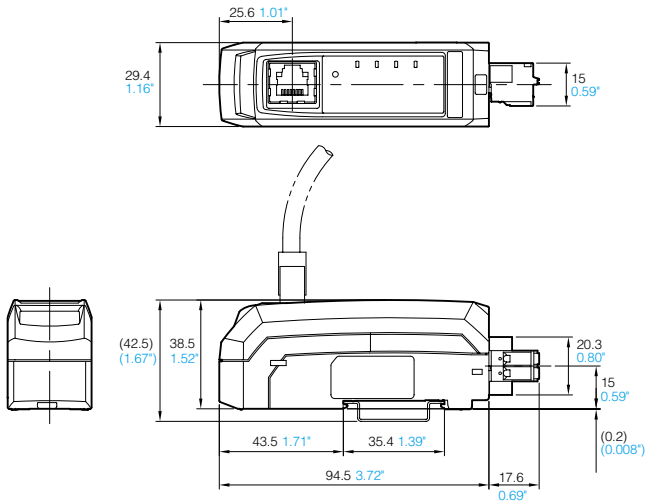

NU-EC1

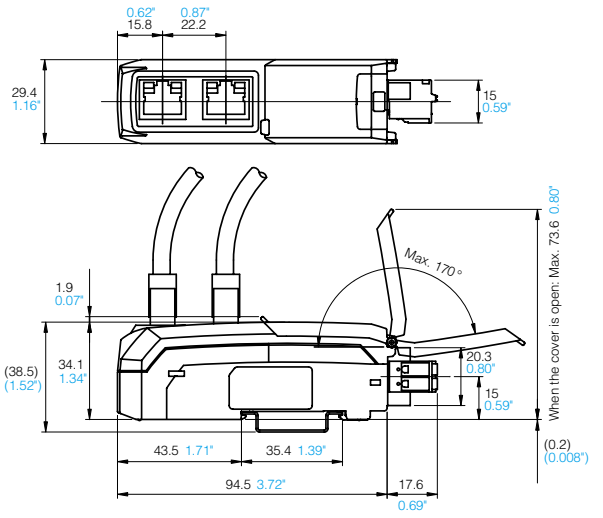

NU-DN1

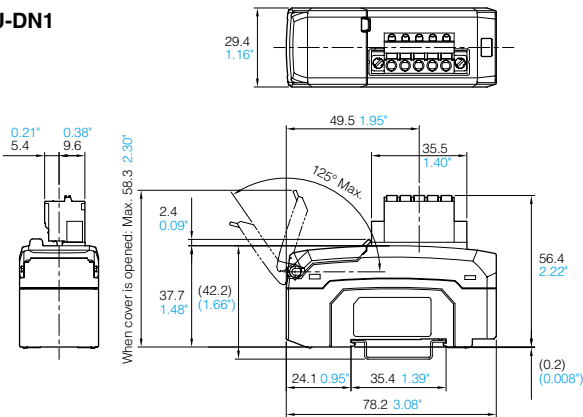

NU-CL1

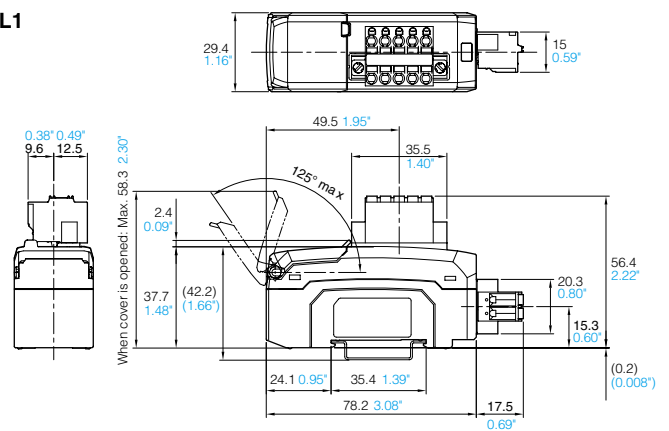

NU-EN8N

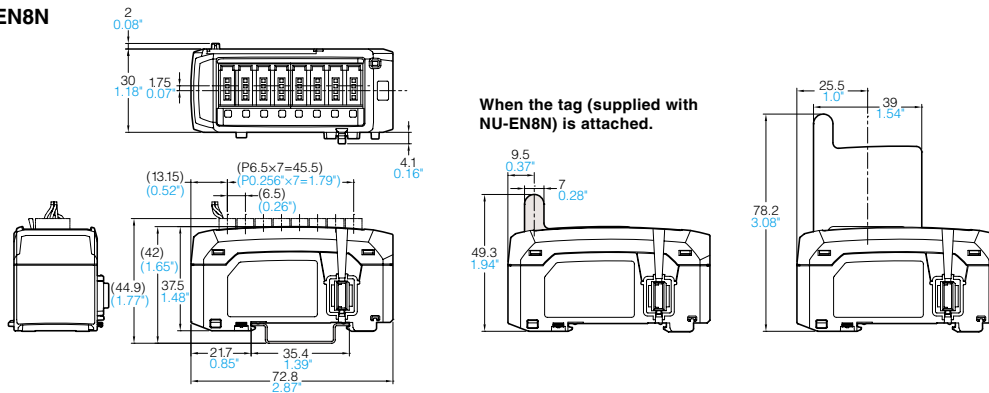

CALL TOLL FREE TO CONTACT YOUR LOCAL OFFICE
1-888-KEYENCE
1-888-539-3623

www.keyence.com



SAFETY INFORMATION

Please read the instruction manual carefully in order to safely operate any KEYENCE product.

CONTACT YOUR NEAREST OFFICE FOR RELEASE STATUS

KEYENCE CORPORATION OF AMERICA

Head Office 500 Park Boulevard, Suite 200, Itasca, IL 60143, U.S.A.

PHONE: +1-201-930-0100 FAX: +1-855-539-0123 E-mail: keyence@keyence.com

AL Birmingham	CA San Jose	CO Denver	IL Chicago	MI Detroit	MO St. Louis	NC Raleigh	PA Philadelphia	TN Nashville	WI Milwaukee
AR Little Rock	CA Cupertino	FL Tampa	IN Indianapolis	MI Grand Rapids	NJ Elmwood Park	OH Cincinnati	PA Pittsburgh	TX Austin	
AZ Phoenix	CA Los Angeles	GA Atlanta	KY Louisville	MN Minneapolis	NY Rochester	OH Cleveland	SC Greenville	TX Dallas	
CA San Francisco	CA Irvine	IA Iowa	MA Boston	MO Kansas City	NC Charlotte	OR Portland	TN Knoxville	WA Seattle	

KEYENCE CANADA INC.

Head Office PHONE: +1-905-366-7655 FAX: +1-905-366-1122 E-mail: keyencecanada@keyence.com

Montreal PHONE: +1-514-694-4740 FAX: +1-514-694-3206 Windsor PHONE: +1-905-366-7655 FAX: +1-905-366-1122

KEYENCE MEXICO S.A. DE C.V.

PHONE: +52-55-8850-0100 FAX: +52-81-8220-9097

E-mail: keyencemexico@keyence.com

The information in this publication is based on KEYENCE's internal research/evaluation at the time of release and is subject to change without notice. Company and product names mentioned in this catalog are either trademarks or registered trademarks of their respective companies. The specifications are expressed in metric units. The English units have been converted from the original metric units.

Copyright (c) 2010 KEYENCE CORPORATION. All rights reserved.

KA1-1017

FSN-KA-C2-E 1087-4 611486